

## Design of a small wind turbine used for a new wind scavenger system



Ibrahim Alatawi\*

Mechanical Engineering Department, Engineering College, University of Hail, Hail, Saudi Arabia

### ARTICLE INFO

#### Article history:

Received 6 March 2020

Received in revised form

25 May 2020

Accepted 1 June 2020

#### Keywords:

Wind

Turbine

Scavenger

Lightweight

Litters

### ABSTRACT

The implementation of renewable resources to assist in cleaning pollution has a direct environmental impact where cleaning devices need to be installed remotely. Wind energy is one of the great potential renewable energy sources, which still not well utilized yet. The present study aims to design a small wind turbine used to drive a new proposed wind cleaner system. The proposed system is suitable for the wind blowing objects such as litters, plastics, and any lightweight garbage. The proposed system is a direct utilization of the system of wind scavenger as U.S. Patent No. 10,378,788. The invention system designed for air cleaning. The main findings of the proposed system analysis prove the feasibility of the proposed system.

© 2020 The Authors. Published by IASE. This is an open access article under the CC BY-NC-ND license (<http://creativecommons.org/licenses/by-nc-nd/4.0/>).

### 1. Introduction

The increase in lightweight wastes due to the growth of civilization and industrial development addresses a question about the future picture of wildlife (Barnes et al., 2009). However, continuing with a huge demand for disposable products will have great environmental issues (Thompson et al., 2009; Oehlmann et al., 2009). A wind cleaning system was introduced by Alatawi (2019) named as wind scavenger, where the main idea is to use wind power to collect wind blowing waste. Utilizing a moving net of which can be placed in the wind direction. The device can be easily installed in remote areas with low maintenance and operation requirements. In addition to using wind to collect lightweight wastes, the proposed device uses wind power to derive a self-cleaning system from keeping collected waste away from sight and wild animals. The wind scavenger self-cleaning system imposes the need for using a Small Wind Energy Portable Turbine (SWEPT). Two types of wind turbines are available; Vertical Axis Wind Turbine (VAWT) and Horizontal Axis Wind Turbine (HAWT). The rotor of the VAWT rotates perpendicular to the ground while HAWT's rotor rotates parallel to the ground (Schubel and Crossley, 2012). HAWT type is the popular design because it has higher efficiency in comparison with VAWT type. The maximum power coefficient of

a modern HAWT ranges from 45% to 50% compared to the VAWT type, which has less than 40% (Kishore et al., 2013). HAWT has a longer life with issues related to blade profile, which needs a twisting angle depending on the distance from the rotor centerline. HAWT needs a wind direction tracking system to turn the rotor to face the wind. Small size HAWT uses a tail with a fin mounted at the back of nacelle, producing a corrective moment adjusting the rotor direction automatically (passive yaw system). The large-scale HAWT type needs an active yaw mechanism with a wind sensor and a servomotor (Gasch and Twele, 2011). Burton et al. (2011) introduced a detailed study about the small-scale wind energy portable turbine (SWEPT) operates at wind speeds below 5m/s. The results showed a maximum coefficient of performance of 14% at an optimal tip speed ratio of 2.9. The output power was 1.25W at 5m/s wind speed. The HAWT is the common type (75%) used worldwide (Gasch and Twele, 2011). The classic three-bladed HAWT design is common for 99% HAWT designs. Some small turbines incorporate an increased number of blades, which may improve aerodynamic efficiency slightly (Chaudhary and Roy, 2015). Alaskari et al. (2019) have concluded that the VAWT is more efficient than the HAWT for low wind speeds due to its ability to capture wind flowing from any direction. However, the VAWT design has a high drag force compared with HAWT. Small wind turbine type covers various applications, including on or off-grid residences, telecom towers, offshore platforms, rural and isolated areas, remote monitoring, and many others with no electric grid (Schubel and Crossley, 2012). The present study introduced a design of a small wind turbine application for air scavenger device

\* Corresponding Author.

Email Address: [ib.alatawi@uoh.edu.sa](mailto:ib.alatawi@uoh.edu.sa)<https://doi.org/10.21833/ijaas.2020.09.007>

Corresponding author's ORCID profile:

<https://orcid.org/0000-0002-8733-2977>

2313-626X/© 2020 The Authors. Published by IASE.

This is an open access article under the CC BY-NC-ND license

[\(http://creativecommons.org/licenses/by-nc-nd/4.0/\)](http://creativecommons.org/licenses/by-nc-nd/4.0/)

that is suitable for small communities as a small module of 20m<sup>2</sup> that can be repeated for larger scales.

## 2. New wind scavenger system

The proposed wind scavenger system is designed to collect lightweight garbage objects. Fig. 1 shows a schematic diagram of the proposed new wind scavenger system consists of three main parts. The small wind energy portable turbine (SWEPT) utilizes the wind energy by transforming the kinetic energy in the wind to mechanical rotating torque on the

rotor shaft. The rotor speed is then reduced through an upper gear system with a gear speed ratio of 1:500, causing a low-speed rotation of a net driving drum shaft. The wind scavenger net will trap the lightweight blowing litters on the frontal side and by moving downward until entering the garbage collecting box leaving all trapped litters inside the box, then turns upward around the lower driving drum where it's pulled by the upper drive drum. The net is mounted on two driving drums of the same diameter (0.15m). The upper gear system drives the upper drum, and the moving net drives the lower drum.

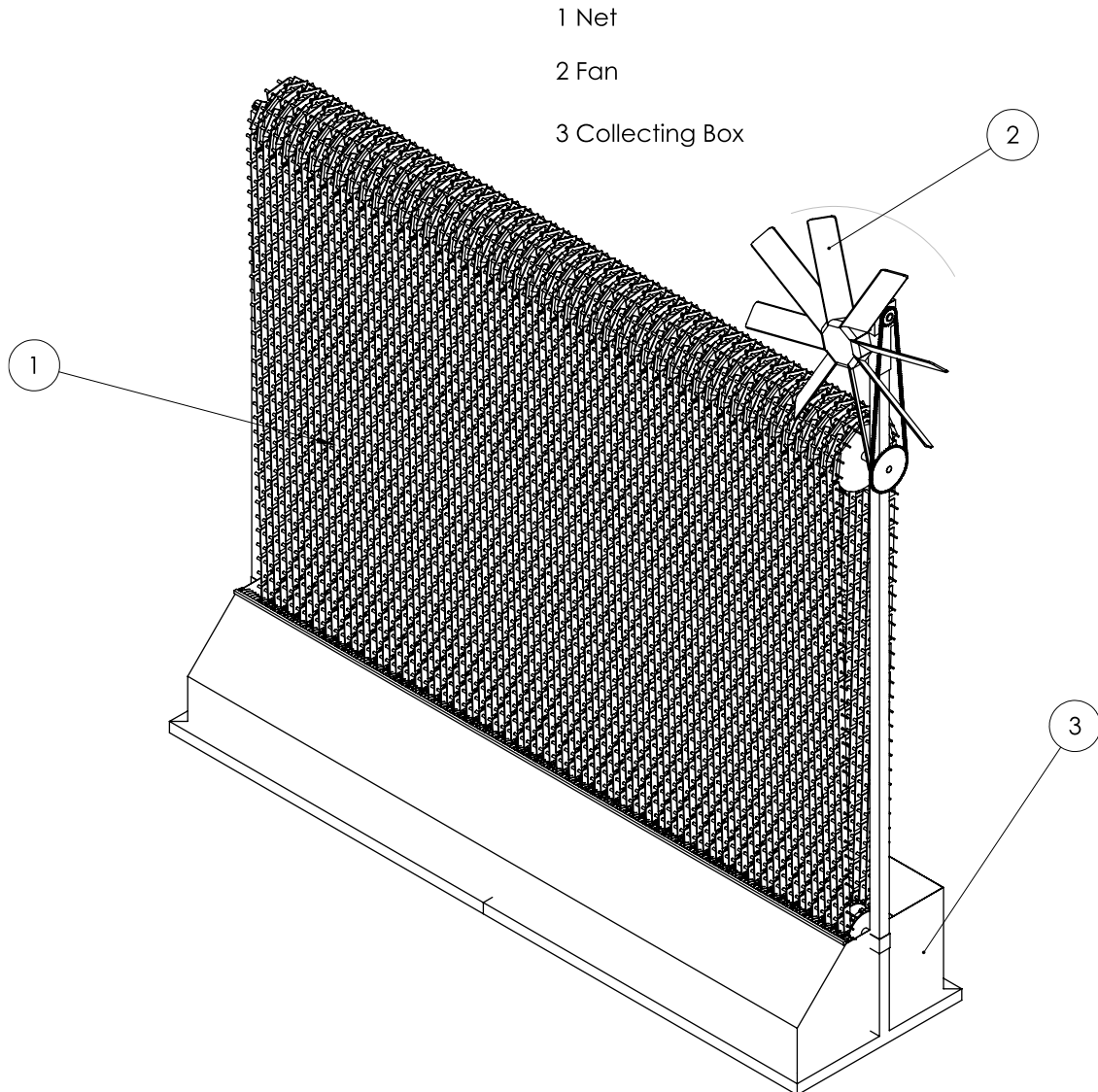

Fig. 1: Schematic diagram of the proposed wind scavenger design (Alatawi, 2019)

## 3. Proposed system design

### 3.1. Design of rotor blades of the SWEPT

Rotor blades are the most crucial parts of wind turbines since they are the key component in wind turbine systems. In addition, their performance has a direct and significant impact on overall turbine efficiency.

In this study, QBlade software (Marten et al., 2013) has been used to design and simulate the

turbine blades. QBlade is an open-source framework for designing and simulating horizontal and vertical wind turbines mathematical models.

### 3.2. Design of the gear ratio

Gear ratio has been designed to satisfy the low speed required for the scavenger net movement. The higher wind turbine rotational speed leads to a higher turbine performance. The speed ratio gear was selected as 1:500 to satisfy higher turbine speed

from 200 to 1000 rpm range keeping the net driving shaft speed at the low rotational speed of 0.4 to 2 rpm, respectively. These rotational speeds will produce a linear net movement speed of 0.19 to 0.94 m/s when using a net driving drum diameter of 0.15 m leading to a 0.15m separation distance between both net sides (Upward and downward sides). The net driving drums are designed of the same diameter (0.15m). The upper drum is driven by the upper gear system connected to the SWEPT shaft with a gear ratio of 1:500, and the lower drum is driven by the net. The two drum shafts connected to each other with a chain gear (the net) with a gear ratio of 1:1 keeping both drums at the same speed. The chosen very low gear ratio will satisfy a saving of the torque of the SWEPT at a lower rotational speed of 200rpm when the wind flows at minimum needed speed to blow up the waist.

#### 4. Theoretical analysis

The speed of rotation of the rotor of the wind turbine is the key factor of the turbine design for best performance device. The speed of the blade's tip relative to the absolute speed of the wind is known as the tip speed ratio ( $\lambda$ ) which can be defined as:

$$\lambda = \frac{\omega R}{V_o}, \quad (1)$$

where,  $\omega$  is the angular velocity of the wind turbine rotor,  $R$  is the radius of the rotor, and  $V_o$  is the free wind speed.

A higher tip speed ratio means the aerodynamics force on the blades is almost parallel to the rotor axis. The relationship between rotational speed and tip speed ratio is defined as:

$$\lambda = \frac{2\pi n R}{60 V_o}, \quad (2)$$

where,  $n$  is the rotational speed of the rotor (rpm). The available wind power entering the turbine could be defined according to Eq. 3 as follows:

$$P = \frac{\pi}{2} R^2 V_o^3 \quad (3)$$

where,  $P$  is the available airpower passing the turbine blades.

#### 5. Numerical simulation

Qblade software uses blade element momentum method (BEM), which is widely used in industry, for 2D simulation of horizontal wind turbines. As described by Hansen (2008), the BEM combines the blade element theory, to account for the local blade forces, with a momentum balance over the rotor disc that models the flow field (Alshammari et al., 2018). It is worth mentioning this type of problem can be solved iteratively. The BEM assumes uniform, steady-state inflow and radial independence of the two-dimensional airfoil sections. The Qblade output has been validated with experimental data, as can be seen in Marten et al. (2013).

For the design of airfoils and computation of lift and drag coefficients, the viscous-inviscid coupled panel method code XFOIL is integrated within the graphical user interface of QBlade. The XFOIL (Hansen, 2008) code combines a potential flow panel method and an integral boundary layer formulation for the analysis of the flow around airfoils. The code was developed to rapidly predict the airfoil performance at low Reynolds numbers, and its convergence is achieved through the iteration between the outer and inner flow solutions on the boundary layer displacement thickness. In this study, SG6043 airfoil (Fig. 2) has been selected since it presents a maximum lift coefficient of 1.85.

It is worth mentioning that the wing is "meshed" into a number of panels distributed over the span and the chord of the planform. XFOIL integrates polar mesh for the calculation with 280-panel nodes, panel-bunching parameter equals to 1, and TE/LE panel density ratio equals to 0.15.

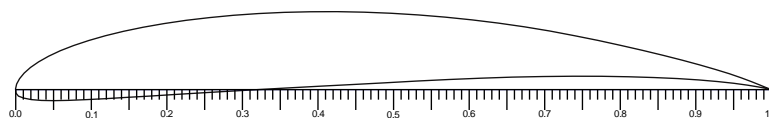

Fig. 2: Schematic diagram of the selected airfoil (SG6043)

In order to obtain a realistic design, semi-empirical correctional losses (i.e., Prandtl blade tip loss, Prandtl root loss) have been applied. In order to improve the performance of the wind turbine, the turbine rotor has been optimized in terms of blade number, blade twist angles, and blade chord (Fig. 3).

#### 6. Results and discussion

As a first step, the behavior of the selected airfoil was investigated. The aerodynamic force, which is resolved into lift and drag, results from the deflection of the airfoil because of oncoming air. Fig. 4 presents the behavior of the airfoil in terms of lift

and drag coefficients. Obviously, the maximum obtained lift coefficient was 1.85 at an angle of attack of 17 degrees. On the other hand, the maximum drag coefficient was 0.11 at an angle of attack of 20 degrees. The abovementioned results clarify the reasons behind the selection of the SG6043 airfoil.

The rotor blades were optimized in terms of twist angles and chord length. Fig. 5 shows the distribution of the twist angles around the airfoil. The maximum twist angle was 57 degrees. However, the maximum twist angle was kept 45 degrees for easier manufacturability. On the other hand, the minimum length of the chord after optimization was

0.011m. In order to facilitate the manufacturability, the minimum chord length was kept 0.02m.

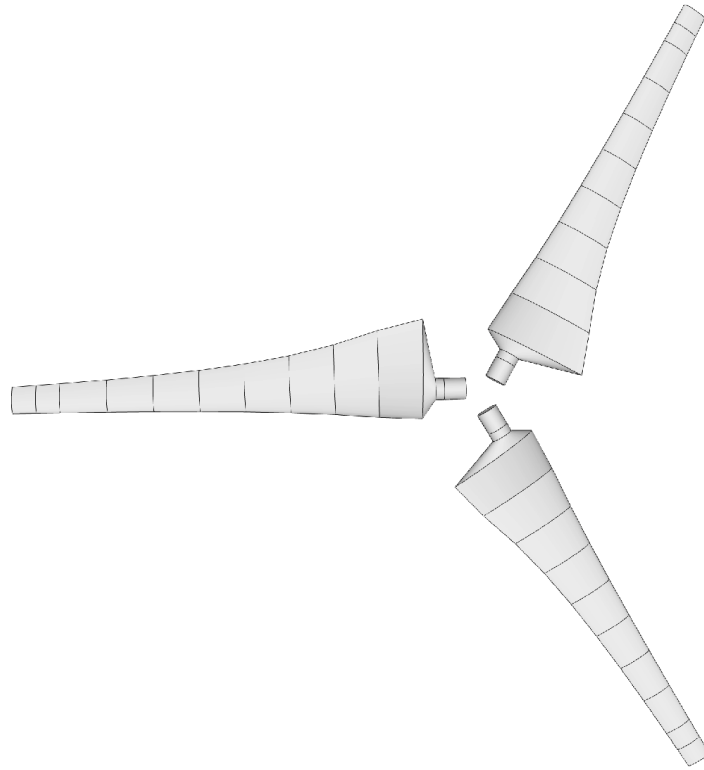

Fig. 3: 3D geometry of the three blades wind rotor design using QBlade simulation

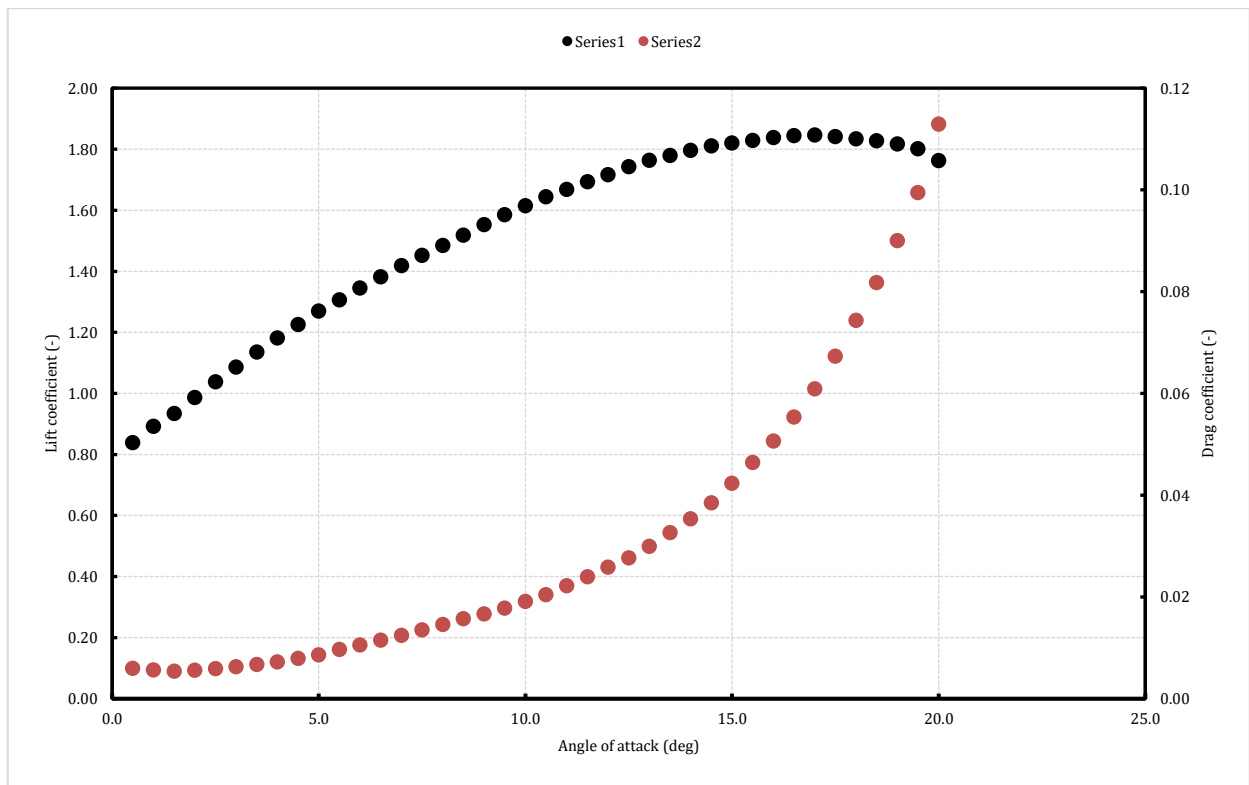

Fig. 4: Effect of position on the distribution of the twist angle and chord length

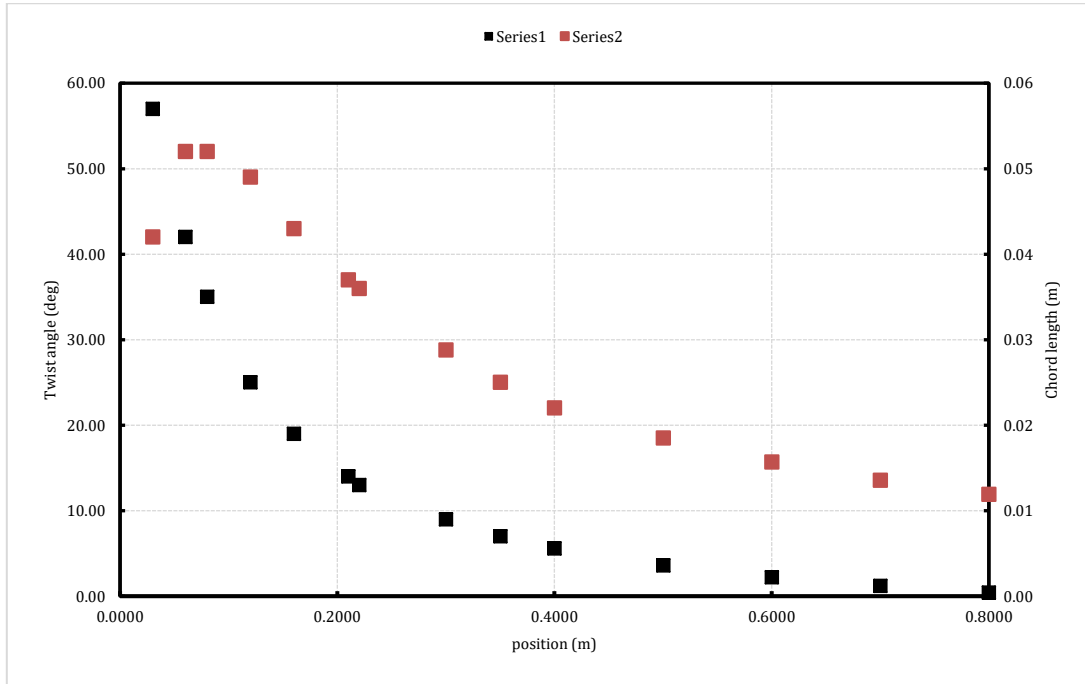

Fig. 5: Effect of position on the distribution of the twist angle and chord length

Fig. 6 presents the effect of tip speed ratio on the performance of the wind turbine. The BEM-based design routine was utilized for a set of tip speed ratios ranging from 1 to 10 while keeping the wind speed and rotational speed fixed. Fig. 6 clearly shows that the power initially increases, reaches a maximum value of 243W, and then decreases with increasing the tip speed ratio.

Finally, yet importantly, the performance of the wind turbine was explored against the wind speed according to the rotational speed, as shown in Fig. 7. As expected, as wind speed increases, the produced power increases as well. Likewise, increasing the blade's rotational speed results in a higher power. At lower wind speeds (<7m/s), the value of rotational speed has a limited effect on power. As wind speed increases, the effect of rotor rotational speed becomes clearer. Fig. 3 presents the final optimized blades of the developed wind turbine.

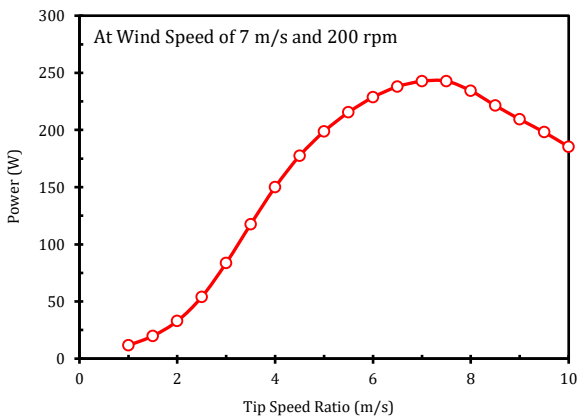

Fig. 6: Effect of tip speed ratio on the SWEPT power at 7 m/s wind speed and 200 rpm

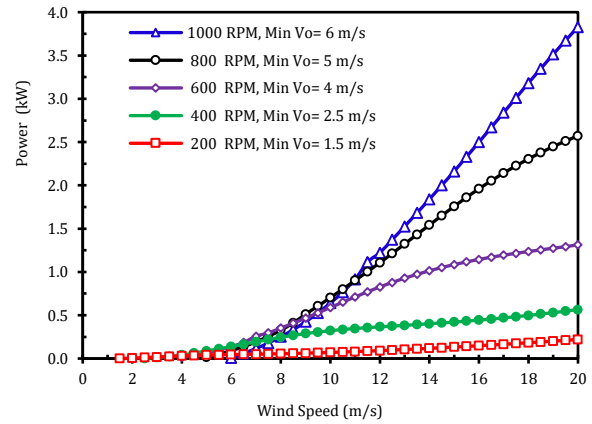

Fig. 7: Effect of wind speed on the turbine power for various rotor rotational speeds

### 7. Conclusion

This paper presents a study of the design and optimization of a small scale wind turbine based on blade element momentum theory (BEM). The proposed airfoil was optimized in terms of twist angles and chord length. Ten different sections of 1.17m blade length were used based on the results of the optimization of the twist angle and chord length of the blade. It was found that the maximum value of (CL/CD) can be obtained when the angle of attack ( $\alpha$ ) is equal to 4°.

The performance of the turbine was explored at different rotational speeds, wind speeds, and tip speed ratios. The maximum obtained power was 3.7kW at 1000rpm, 20m/s wind speed, and tip speed ratio equals to 7. The obtained results indicate that the designed blade (including the resulted power output) is sufficient for running the scavenger system.



## List of symbols

<i>BEM</i>	<i>Blade element momentum</i>
<i>HAWT</i>	<i>Horizontal axis wind turbine</i>
<i>SWEPT</i>	<i>Small wind energy portable turbine</i>
<i>TPES</i>	<i>Total primary energy supply</i>
<i>VAWT</i>	<i>Vertical axis wind turbine</i>
<i>R</i>	<i>Radius of the rotor</i>
<i>V<sub>0</sub></i>	<i>Absolute wind speed.</i>
<i>P</i>	<i>Available wind power</i>
<i>ω</i>	<i>Angular velocity of the wind turbine rotor</i>
<i>λ</i>	<i>Tip speed ratio</i>

## Acknowledgment

Acknowledgments to Deanship of Scientific Research, University of Hail, Saudi Arabia, for supporting this work.

## Compliance with ethical standards

## Conflict of interest

The authors declare that they have no conflict of interest.

## References

- Alaskari M, Abdullah O, and Majeed MH (2019). Analysis of wind turbine using QBlade software. In the IOP Conference Series: Materials Science and Engineering, IOP Publishing, 518(3): 032020. <https://doi.org/10.1088/1757-899X/518/3/032020>
- Alatawi I (2019). Wind scavenger. U.S. Patent No. 10,378,788, U.S. Patent and Trademark Office, Washington, USA.
- Alshammari F, Karvountzis-Kontakiotis A, and Pesyridis A (2018). Effect of radial turbo-expander design on off-highway vehicle organic Rankine cycle system efficiency. *International Journal of Powertrains*, 7(1-3): 72-93. <https://doi.org/10.1504/IJPT.2018.090364>
- Barnes DK, Galgani F, Thompson RC, and Barlaz M (2009). Accumulation and fragmentation of plastic debris in global environments. *Philosophical Transactions of the Royal Society B: Biological Sciences*, 364(1526): 1985-1998. <https://doi.org/10.1098/rstb.2008.0205> **PMid:19528051** **PMCID:PMC2873009**
- Burton T, Jenkins N, Sharpe D, and Bossanyi E (2011). *Wind energy handbook*. John Wiley and Sons, Hoboken, USA. <https://doi.org/10.1002/9781119992714>
- Chaudhary M and Roy A (2015). Design and optimization of a small wind turbine blade for operation at low wind speed. *World Journal of Engineering*, 12(1): 83-94. <https://doi.org/10.1260/1708-5284.12.1.83>
- Gasch R and Twele J (2011). *Wind power plants: fundamentals, design, construction and operation*. Springer Science and Business Media, Berlin, Germany.
- Hansen MOL (2008). *Aerodynamics of wind turbines*. Earthscan, London, UK.
- Kishore RA, Coudron T, and Priya S (2013). Small-scale wind energy portable turbine (SWEPT). *Journal of Wind Engineering and Industrial Aerodynamics*, 116: 21-31. <https://doi.org/10.1016/j.jweia.2013.01.010>
- Marten D, Wendler J, Pechlivanoglou G, Nayeri CN, and Paschereit CO (2013). QBLADE: An open source tool for design and simulation of horizontal and vertical axis wind turbines. *International Journal of Emerging Technology and Advanced Engineering*, 3(3): 264-269.
- Oehlmann J, Schulte-Oehlmann U, Kloas W, Jagnytsch O, Lutz I, Kusk KO, and Tyler CR (2009). A critical analysis of the biological impacts of plasticizers on wildlife. *Philosophical Transactions of the Royal Society B: Biological Sciences*, 364(1526): 2047-2062. <https://doi.org/10.1098/rstb.2008.0242> **PMid:19528055** **PMCID:PMC2873012**
- Schubel PJ and Crossley RJ (2012). Wind turbine blade design review. *Wind Engineering*, 36(4): 365-388. <https://doi.org/10.1260/0309-524X.36.4.365>
- Thompson RC, Moore CJ, Vom Saal FS, and Swan SH (2009). Plastics, the environment and human health: Current consensus and future trends. *Philosophical Transactions of the Royal Society B: Biological Sciences*, 364(1526): 2153-2166. <https://doi.org/10.1098/rstb.2009.0053> **PMid:19528062** **PMCID:PMC2873021**