

## Influence of the climate on large scale cable structures: A case study of Khan Shatyr entertainment center in Astana, Kazakhstan



Çilen Erçin\*, Karina Nurumova

Department of Architecture, Faculty of Architecture, Near East University, Nicosia, Turkish Republic of Northern Cyprus

### ARTICLE INFO

#### Article history:

Received 21 September 2019

Received in revised form

20 January 2020

Accepted 22 January 2020

#### Keywords:

Cable structures

Structural system

Climatic problems

Large scale construction

Khan Shatyr

### ABSTRACT

The purpose of our study is based on the structural examination of large scale cable structures built in different climatic conditions. Firstly, the study identifies construction methodology and typical problems related to cable structures. Later history, function, construction methodology, and materials have been studied in order to investigate the conception of the structural cable system to evaluate large scale structures worldwide. Historical background review has been done to chronologize the development of cable structures and the appearance of new elements and materials used in combination. The influence of the climatic conditions of specific regions on cables has further been examined in order to indicate possible solutions for the existing problems. As a result, tables on a comparative study of large scale cable structures in different regions have been presented. Khan Shatyr Entertainment Center, located in the capital of Kazakhstan, was chosen as a case study to reveal the construction methodology of large scale cable structures considering the impact of the climate. Evaluation of the case study displays that climatic impact was properly considered on the design stage, increasing structure stability. In addition, the article suggests that this type of structural system is suitable for all climatic regions.

© 2020 The Authors. Published by IASE. This is an open access article under the CC BY-NC-ND license (<http://creativecommons.org/licenses/by-nc-nd/4.0/>).

### 1. Introduction

Cable structure is the pure and simple system in its form and complex composition in the application. Article states as the main problem structural system construction considering climatic specifications and reveals the important aspects of building formation.

The consideration of appropriate climatic conditions and problems related to climate occurred in cable structures is the fundamental factor that increases the functionality, productivity, and maintenance of the building.

The aim of this research is to make an investigation of the construction methodology and structural features of large scale cable structures of diverse regions. A comparative study on the existing cable structure buildings built in different climatic conditions identifies its specific construction properties and examines materials to be used with the main structural system. In this article, Khan

Shatyr Entertainment Center in Astana city in Kazakhstan is investigated for example.

#### 1.1. The importance of the study

The research provides a prior knowledge about the cable structural system details. It also gives a chronological overview of system development. On the example of the Khan Shatyr Entertainment Center in Astana, we have shown the contemporary construction methodology of the cable systems. This article reveals the solutions to the climate-related problem that occurred in different conditions and may serve as the guide for future works.

#### 1.2. Overview of the cable structure

##### 1.2.1. Definition of the structural system

Cable structural system uses tension elements to carry and transfer the main forces applied to the building. The dead loads of the prevalent structure, as well as the live and other types of loads, are transmitted by the columns. Unfortunately, in some building types, such system type may be inopportune. As an example, we can review a stadium. Major columns taking loading of the building may not be placed in the center of a plan to

\* Corresponding Author.

Email Address: [cilen.ercin@neu.edu.tr](mailto:cilen.ercin@neu.edu.tr) (Ç. Erçin)

<https://doi.org/10.21833/ijaas.2020.04.010>

Corresponding author's ORCID profile:

<https://orcid.org/0000-0002-9799-1810>

2313-626X/© 2020 The Authors. Published by IASE.

This is an open access article under the CC BY-NC-ND license

(<http://creativecommons.org/licenses/by-nc-nd/4.0/>)

not overlap the circulation. The exoskeleton system probably is the solution in this case, yet the roof would be too massive, and the building must be scaled as well. Thereby structural cable system may replace exoskeleton. Cables are set to the base in a distance of the formation to haul the roofing driving out forces to anchorage points. This chance allows compression impact to be transformed on tension, and loadings are moved from the middle of the building to the edges.

The cables by itself represent linear tensile elements. They are usually produced from steel types and have a great ability to withstand big forces and support the structures even in the rough climatic conditions. Cable structures can use single cables arranged parallel, which take a funicular form or two-way net arrangement. The second type takes no deviations of shape and acts more stable because here, loads from internal forces carried by structure can pass through different pathways.

### 1.2.2. Properties

Structural elements like cables are made of stainless steel, mild steel, exposed carbon, and high strength steel. They are produced from a chain of tiny threads or strands which are linked to create longer and bigger system detail. Steel cables have several types of strands: Spiral strands with inwrought round kernels and stuck by polymer, seven-stranded rope with twisted strands, and full-locked coil strand or z-shape strands with interlocking threads. Working principle of the cables based on the canon that cables do not take compression force while it is under tension. Cables are subjected to the third law of Newton when all forces applied to the object have an equal response with the opposite vector. For the cables, it indicates that tension loading assumed to one end of the cable has identic force across the length to counter ending. Structural cables represent rope-like materials that behave in its natural, free condition as flexible and shapeless form. Structurally cable acts as a non-rigid member that takes only tension. It has no rigidity. A cable sagging under its own weight takes a chain like a catenary shape. It is expected to take on a paraboloid shape when uniformly loaded. Equations can be derived from these basic assumptions that relate to the tension, change in length, and sag.

### 1.2.3. Usage

Steel cables can be used in two ways in building construction. First is the suspension type of structure roof with the conventional or a complex structural system. This way, the main roofing is suspended by steel cables over the roof vice being supported by structural members. Cables transfer tension force to the anchorages on the ground. These types of the structures are called cable-tayed roofs. Cables act as simple suspension elements in cable-stayed kind of buildings whereas roof conducts as regular load-bearing unit, exposed under moment,

shear and other influences. Yet under the wind load suspended elements keep the tension through the loadings applied to the structure. Industrial buildings with the suspended roof are mostly the examples of this type of construction. The second possibility of cables usage in building construction is represented in the roof types where the steel cables are presented as an acting parts of the structure. They are not only transporters of the loads of the structure to the foundation but the main system shaper. Such systems are called tensile structures and cables here confront different outer factors. Behavior of the cables impacts form of the building with the new methods of fulfillment imposition.

In the geometry, design, and analysis, cable structures can be simple as well as complicated. Most of the type of cables structural design requires special computer modeling. The typical uses of this structural system are bridges, long-span roof structures, membrane roofs, railings, cable net curtain walls, etc. Cables are also used in concrete structures in steel, reinforcing to achieve longer spans with thin members (Phocas, 2013). Cable structures represent light, efficient, more economical buildings with great flexibility.

### 1.3. Research methodology

To understand the subject and focus points that might be interesting to investigate the qualitative research method was used. Literature studies were conducted, including the reading of books, reports, scholarly articles, various internet sources, and previous researches.

To accumulate relevant data, the on-site observation and photographic documentation of Khan Shatyr Center in Astana, Kazakhstan, was done. The intensive search of cable structure properties through a literature survey helped in the analysis and determination of construction principles and specifications of this system.

## 2. Historical background

### 2.1. The beginning of cables usage

The appearance of new materials and construction technologies in history has often led architects and civil engineers to rethink the meaning of architecture. In the last 100 years, cable structures have been developed as a new structural system from small to dramatically large scale. Engineers inspired by the idea of minimalistic architecture and fewer materials usage have sought ways to do in Buckminster Fuller's terms more with less.

Prototypes of the cable suspended and cable-stayed buildings had been nomadic tents and cable bridges. Suspended bridges well-developed technologies influenced the innovative design of tensile structures. It allowed structural engineers to apply the same principles for the construction of large scale cable systems. Fig. 1 shows the cable

suspended Mount Hope Bridge spanned the Narragansett Bay in Rhode Island, USA. By the time

of its construction, it was the fourth-largest cable bridge in the USA.



Fig. 1: View of the Mt. hope bridge, Rhode Island (Nurumova, 2017)

## 2.2. Appearance of first large scale cable structures

Between 1963 and 1967, Frei Otto developed the forms and techniques of cable structural systems. The use of cable-nets at Lausanne in 1964 allowed a bigger span to be achieved with less stress placed to structural elements (Fig. 2). These early structures laid the foundation to discover the new structural principles which soon could be applied to much larger scales (Filler, 2015).

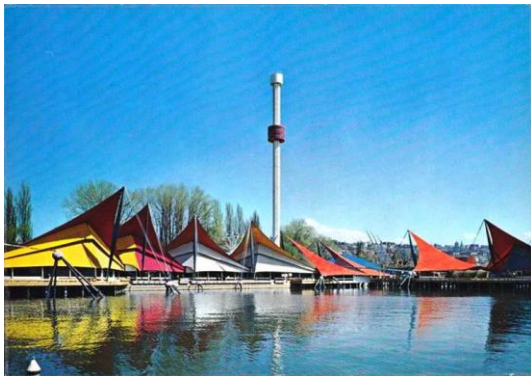

Fig. 2: Cable structures of Lausanne expo, 1964 (Filler, 2015)

The first large scale cable-net roof used in construction, rather than simple shelter, appeared at the Montreal World Expo in 1967 (Filler, 2015).

This extraordinary nonclassic construction by Frei Otto and Rolf Gutbrod was used to hold the German Pavilion during the exhibition and had similar principles of the construction to Lausanne structure. By using a cable-net to support the pre-stressed membrane suspended below it, architects were able to achieve a large scale. Before the final construction, tests were carried out on a prototype. Today this building is used to house the Institute for Lightweight Structures (Fig. 3).

After this success of Montreal, a spectacular application of cable-net structures appeared in a bigger arena, covering stadium and sports halls for the 1972 Olympic Games in Munich. This project of German architect Gunther Behnisch and Frei Otto took the techniques of cable structures one step

further by showing how it could be combined with glazed curtain walls to create fully closed spaces (Warmbronn, 2015).



Fig. 3: View of the Montreal expo Pavilion, 1967 (Warmbronn, 2015)

The main stadium in Munich, shown in Fig. 4, needed a transparent roof to avoid shadows of the broadcast events. This was achieved by the use of the transparent sheeting made of acryl and supported on top of the cable-net structure. These extraordinary roofs demonstrated some new forms and proved that these structural techniques could be successfully used in large scale applications.

## 2.3. Combination of cable structures with traditional architecture

With the development of the materials and technologies, it became possible to rethink the architecture of previous periods and adapt them to modern needs. Tendencies of combining the cable structural systems and traditional masonry architecture began in the 1980's. However, during the construction of first buildings, difficulties and problems were found. And most important is cable to frame connection of different materials. This process requires the completion of sockets and frame contemplation. Cable completion sockets are produced from steel corresponded at the end of a cable to tie the strands together. The length of the conic type is nearly 5-6 times bigger than the cable diameter (Goldsmith, 2000).



One of the earliest examples of cable structures and conventional architecture was part of the Italian architect Renzo Piano's renovation of the Schlumberger research facilities in Montrouge

showed within a suburb of Paris in 1984. From a distance, the cable roof appeared not so different from some of the early buildings made by Frei Otto.

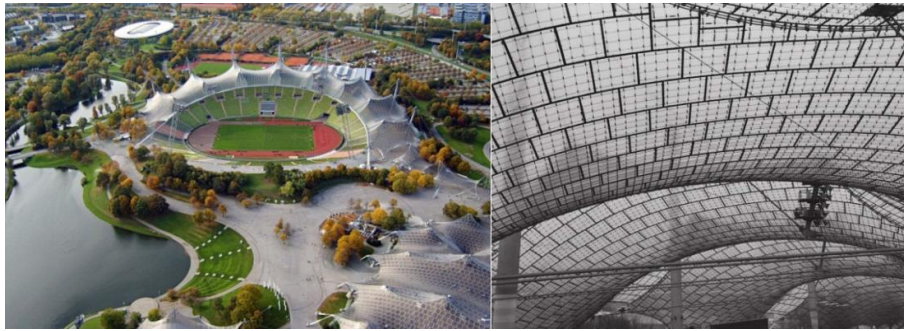

Fig. 4: Munich Olympic Stadium (Henrysson, 2012)

The idea of using a cable structure in combination with traditional construction had been applied in a very different situation 16 years before the completion of the Schlumberger roof in Paris. To cover the audience area in the Abbey ruin at Bad Hersfeld in Germany during the theatrical events, a retractable canopy was erected with a constant arrangement of steel masts and cables (Fig. 5).

cover the main exhibition hall and to evoke marine fantasies. In this project, a double-layer membrane was used to improve the environmental and acoustic performance of the skin. Canada Pavilion created a sensational view at the time came to find a permanent urban application for an established cable-net structure deducted for permanent use as a convention center after the Expo had finished.



Fig. 5: Bad Hersfeld audience amphitheater in Abbey Ruin, Germany (Nerdinger, 2005)



Fig. 6: Combination of the masonry and cable structures in Riyadh Club (BHE, 2015)

The first built permanent structure designed to utilize masonry construction in combination with structural cables was built to house the Diplomatic Club in Riyadh (Fig. 6). This building, completed in 1986, advanced the use of cable-net construction with masonry, by attaching the lightweight structures directly to a curved inhabited wall. The massive wall provided a curved surface to which the geometry of the conical and saddle-shaped roofs could satisfactorily be connected in both structural and aesthetic terms (Boxer and Scheuermann, 1996).

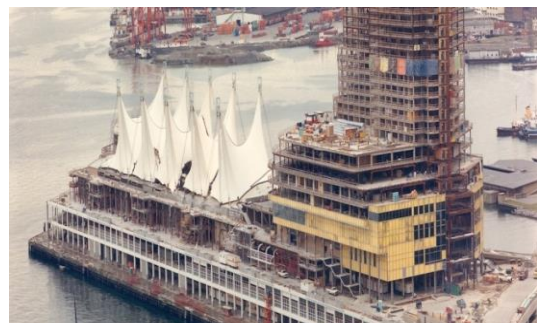

Fig. 7: Canada pavilion in the Vancouver expo, 1986 (Chan, 2016)

The project in Riyadh showed how cable structures could be combined with traditional construction.

## 2.4. Contemporary cable structures

A ship-like building appeared in Vancouver harbor replacing British Columbia Pier during the preparations for the 1986 Expo Vancouver, Canada (Fig. 7). This new building, constructed to host the Canada Pavilion, used a large cable roof structure to

## 3. Construction methodology and system details

### 3.1. Characteristics and working principles of the system

In the last years, cable structures became more useful and attractive. Cable systems are becoming more widespread because of cables' legerity, absolute length, and flexibility. It gives architects more freedom of imagination and work. The compound of cables with roof material signifies the

value of transparency and lightness of forms. Innovations in shape are one more reason for cables' popularity nowadays.

Cables transmit loads only through simple normal stresses either through tension or compression. Any two cables with different points of suspension can be bound together and form a suspension cable structural system. Cables exposed to external loads would deform in a way depending on the magnitude and position of external forces. This form obtained by the cable is called the funicular form of the cable.

### 3.2. Cable structural system details

#### 3.2.1. Materials and components

Since cast steel was used for the construction of the Olympic Park (Munich, Germany), its workability has been enlarged. The great moldability of this metal is a crucial point in the manufacture of the cable components. Cast steel is chosen for the specific properties of this material.

Cast steel allows double-curved and free shaped forms to be constructed to meet certain tasks in loading, design, and components detailing. Cast elements are usually used in members where a large number of bars, rods, or other elements meet each other or when cables join or redirect, and where the cover material is fixed to the primary cables structural system.

The process of modeling and molding is defined by the number of details. The models are usually

constructed of wood, and molds are hand-made from sand in individual boxes in series of up to twenty units.

When the matter cannot be shown in drawings because of its complicated shape, it is possible to make a primary casting test or full-size model before starting mass production.

Stainless steel is used in the production of primary load-bearing elements. When special surface quality is specified, and great resistance to corrosion is required, stainless steel plays a big role.

Pure steel surface may be specified with steel-and-glass forms for the good view of the building. Stainless steel sometimes used for these reasons. This material gives an attractive appearance and a good perception of the whole structure.

#### 3.2.2. Cables

Cables form linear members with high strength. Cables are usually produced by helical layers of single galvanized steel wires and used for the primary structure; they can form locked, open helical cross-section or seven-stranded rope type (Fig. 8).

Open spiral strands are made of lap wires of different diameters. Full locked cables consist of the layers of Z-shaped wires turned around a core of circular wires. Full locked cables have much more metal alloys and higher stiffness than strands with open spirals of the same diameter, considering their high density (Koch, 2004).

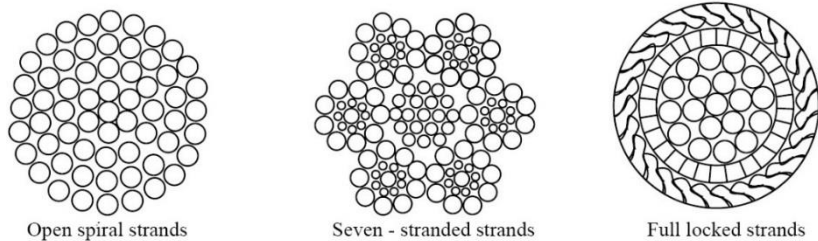

Fig. 8: Types of the cable strands (Lawson and Bilyk, 2014)

#### 3.2.3. Connecting elements

Basic details for connection of the cables to each other and to other members are saddle points with or without clamps Fig. 9 which transfer deflective forces, conical cast sleeves and forked sleeves used for the end fixings in locked cables, threaded fittings and forked eye-clamp used for the end fixings in open cables.

All of these kinds of cable connections have different cases of application conditions. Because of reducing in tensile strength in the cable with integrated wires redundant lateral compression on the wires should be avoided. That's why swaged end fixings are made 10% weaker than needed. The bending radii should be 20–30 times bigger than the cable diameter (Koch, 2004).

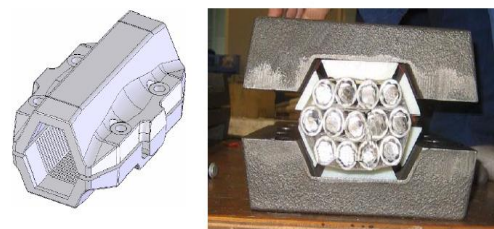

Fig. 9: Cable clamps (Joye, 2010)

In the points of cables intersection, it is necessary to insert crossing elements (Fig. 10). The choice of the crossing type depends on the number of cables connected at that point. It can be either U-bolt connection at the two cables intersection in cable net or single bolt clamp connection for a twinned cable.

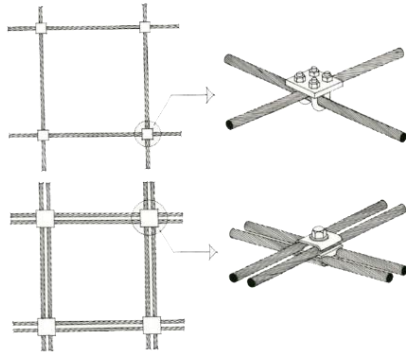

Fig. 10: Cables crossing connection elements (Joye, 2010)

The end fittings of the open cables Fig. 11 are pressed into it; this process is impossible in the case of closed cables because of the cambered effect of the wires. End fittings are suitable for both open and closed types of cables; they are widely used with 40 mm or more diameter variations (Koch, 2004).



Fig. 11: End fittings (Koch, 2004)

### 3.3. Anchorage system

Anchorage system is used for the direct transfer of the loads to the ground. This system can be used for all types of cables structures. Variations of the anchorage depend on the ground conditions of the construction site.

The most used types are (Fig. 12): Gravity anchors; Plate anchors; Mushroom anchors; Retaining wall anchor; Ground anchors; Tension piles.

Gravity anchorage's working principle is to neutralize the vertical constituent element of the loads with the help of its own weight. The horizontal compound is transferred to the ground. Gravity anchorage is used in weak soils like sand and gravel. They are massive and heavy. Plate and mushroom types of anchorage systems lean on the soil's abilities to resist the loads from cables. They are used in the compacted soils like clay. Ground anchorage transfers the horizontal compound of force by the weight of soil and vertical by the shear force among ground and anchor. It is used in the granulated or clay types of soil. The working principle of the tension piles is similar to the ground anchorage, but the horizontal compound is balanced by the

confrontation of the pile and ground with the opposite direction of the force (Goldsmith, 2000).

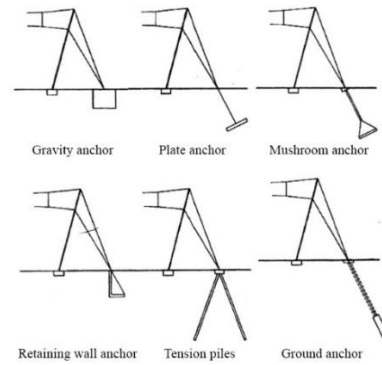

Fig. 12: Types of anchorage systems (Goldsmith, 2000)

### 3.4. Classification of cable structures

By the load-transfer specification, three main classes of cable structures can be presented:

- Catenary typed structures where the main load transfer character is the axial tension. The balance of the structure is gained by the compression beard by the anchoring system or primary supports. The structure is not free-standing. In this case, the load is transported to the borders directly. Cable suspended structures are examples of catenary types.
- Arch typed structures where the main load transfer character is the axle compression. Loads are corresponded by the structural supports in this kind. Arch-liked structures can stand freely under their own weight, but the deformation and self-weight will be greater. Examples of these types are cancellated cable structures.
- Mast types, in which the load transfer pattern is the tension. The structure can be free-standing, usually inclined for maximizing the ability to resist the axial forces.

#### 3.4.1. Catenary types or saddle roof

Cables are the basic structural members because of their dominant supporting tensional forces. The most famous of its types are catenary structures Fig. 13 with several kinds discussed below.

#### 3.4.2. Arch types

Cables sometimes used as reinforcing or stabilizing members in arch-like structures because of the ability to support compression. Cables can enhance hardness and load spread, minimize the impulse of the supporting system. Cables are integrated with arched constructions because the arch can support dimensions of large and high structures. The curvature of the arch is a good form for producing a double-curved cable structure, as it showed in Fig. 14. The Brand hangar can be an example of arched forms of cable structures.



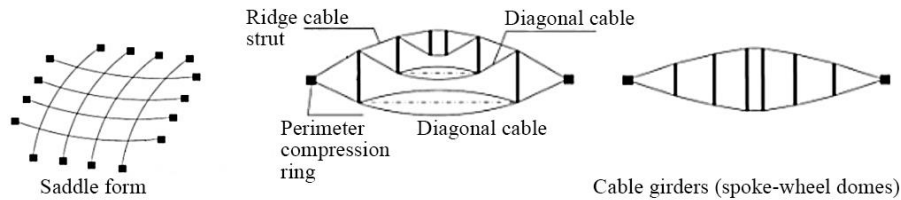

Fig. 13: Catenary-like types of cable structures (Bing, 2004)

The vertical or so-called standing arches are elaborated from a catenary chain and have some disadvantages compared to catenary. A good form of the structure is applicable only by specific loads. Dead load and snow loads are playing a huge role in forming the system while other loads (e.g., one-sided snow or wind loads) can cause bending of the arch.

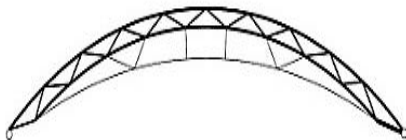

Fig. 14: Arch-like type (Bing, 2004)

The rigid arch formed structures' steadiness can be increased by the mean of side bracing elements as was done in (Fig. 15). Bracing elements are designed as simple geometric forms and used to adjoin arches and transfer lateral stiffness from the arch's deflection from the main ax. Bracing elements in the plane of the main supporting system infringe above the arch.



Fig. 15: Brand hangar (Behrends, 2015)

### 3.4.3. Mast types

Masts are very popular types of primary structures in cable systems. It is easier to create a double-curved surface by raising structure by the use of masts higher than necessary by function. The Millennium Dome in London, United Kingdom Fig. 16 is an example of mast types. The cable-net formed dome structure has a ring of 12 masts with hinged fixings stayed outside in a circular way.

Lateral forces on the mast influence the moments of resistance at the base of the masts if the rigid fixings located too high because strong loads occur there. The design is breaking the moment into a polygon of tension and compression forces with broad feet (Koch, 2004).



Fig. 16: The Millennium Dome, UK (Macdonald, 2003)

There are three types of masts used worldwide: flying, interior, and exterior. The exterior masts are suspended at height (Olympic Estate, Munich). The peak can be seen at the top instead of the joint between the maximum point and the pendant. The interior and flying masts are basically the same since they support the high points of structure.

## 4. Problems related to climatic conditions occurred in large scale cable structures

### 4.1. Statement of the climatic conditions

Permanent and short-term prevailing climatic conditions of the specific areas can be determined by longitude and latitude, position related to continent and ocean, height above the sea level, etc. All of these factors influence not only the construction process of the building but the life and workability of the system and its details. Climatic conditions of specific regions such as wind, rain, snow, humidity, temperature change, etc. influence the capacity of the structure and strength of its members.

Cable structures with their small self-weight and high load-bearing ability became one of the famous structural systems in the design of large scale projects.

Cables under the loads caused by climatic peculiarities undergo some deformation, with the change of load configuration the form of the cable changes as well. Details distortions increase the risk of the structure collapse, reduce structure lifetime, and decline significant value. The tension appeared in the cable supports, and its displacement under the outer impact affects the total stability of a structure. To decrease the impact of the nonlinear properties, the cables are going through the pre-stretch. Optimal values for it can be found from the stress-strain diagram shown in Fig.17.

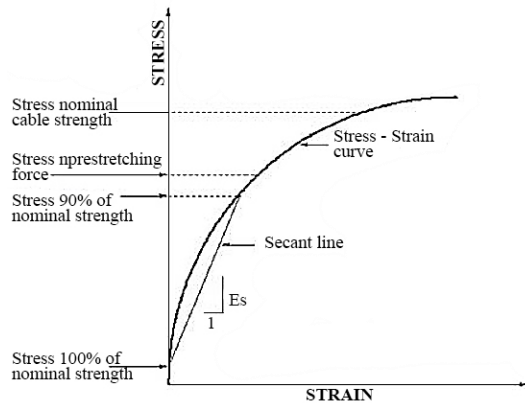

Fig. 17: Curve of the stress-strain dependence (Gossen, 2004)

Cable structures are found to be well resisted to the fire. With the rise of the temperature, prestressed steel cables remit, and the tension of the members decreases gradually. It allows the whole structure of the roof decay slowly and not simultaneously. By the time the strength of cables becomes weakened, all the loads and forces are ended up owing to cables pretension. This process leads to the growth of the safety factor over structure collapse at the beginning of the fire (Vanderberg, 1998).

Flexibility and lightweight of cables and structural members give the good possibility of cable systems to be built in high seismic zones. Cable systems built-in hot climate have an additional effect of “cooling tower” which can be very useful and advantageous. Tent form of the building also works in a way that air-cooled in the night may be kept for the use over the following daytime.

#### 4.2. Vibration due to temperature change

Low fading of cables causes vibration problems in the system. It can be summoned by traffic, earthquake, rain/snow/wind effects, or temperature fluctuations. Dampers systems were adopted from bridge construction to solve this problem. There are three types of dampers that can be used in cables to reduce vibration: Viscous (VD), magnetorheological (MRD) Fig. 18 and tuned mass dampers (TMD). Viscous dampers' fading coefficient allows it to work on a maximum mode. Tuned mass dampers have a great opportunity since they can be installed at any point of cable and does not require fixation to the bridge deck or foundation. TMD, together with escarpment devices, is used for the softening of three-dimensional vibrations (Cai et al., 2007).

Each of the dampers types has its specifications in installation. For example, magnetorheological dampers should be fixed at a distance close to the cable end and 5% lower than its length. To decrease the unnecessary vibration in large scale cable structures, viscous dampers can be applied near the fixation point of every cable between the deck and cable (Sadek et al., 1997).

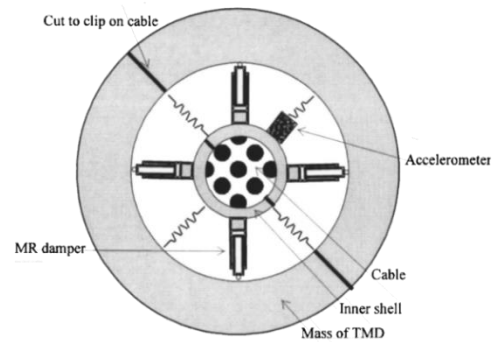

Fig. 18: Details of magnetorheological damper (Cai et al., 2007)

Vibration health monitoring (VHM) can be used for the check of the weakening of the cables, sagging of the bars, and the maintenance of the structure. VHM uses the innate periodicity and mode forms as sensitive to damage features.

To use the VHM, a pre-measurement analysis should be done in advance. Pre-measurement analysis consists of two stages selection of vibration excitation and pointing of sensors. The goal of this measurement is to determine one excitation point for further choosing of sensor point on specified diapason of frequencies.

Some of the pre-measurement methods treat only the sensor placements while others are working with both excitation and sensor location. Methods based on kinetic energy, an eigenvector, or effective independents are used for sensor integration, and methods based on point residues, an eigenvector, or kinetic energy are used for finding the excitation points (Ashwear and Eriksson, 2017).

#### 4.3. Dynamic effect of wind

Fluttering or aerodynamical instability is one of the most important problems in large scale cable structures. This assesses special demands in the design and construction of the building. The main determinative factors are the necessity of the rigidity under transverse loads and anchorage to the foundation. Single cables need to be stiffened to avoid shape modifications and to increase the resistance uplift. Stormy wind can create fluctuations if damping is not accommodated to the construction (Vanderberg, 1998).

Basic methods for providing stability against aerodynamical effects: -Additional load supported on the roof used to balance the effects of asymmetrical actions; -Adding of mass (e.g., concrete slab) helps to stabilize the roof structure but same time increases the weight of it; -Beams-like rigid members where constant load may not be strong enough to neutralize uplift load fully but at sufficient bending stiffness to deal with this load and allow cables to resist the gravity; -Compression of hard structure resists the uplift forces on rigid surface;

In general, cable structures with the defect of wind correlation between parts located in the distance more than 5 m from each other react as a



unified mode resonance. It could be seen in the structure of Raleigh Arena in the USA before stiffening building with internal ties (Seidel, 2009).

Cable structures are found to be more resistant to earthquake excitations than to the winds. Buildings in span more than 25 m have their main down vibrations within the high-energy domain of the wind density. Dynamic analysis under wind loads should be properly done before construction (Osisko and McClure, 2008).

#### 4.4. Corrosion protection

Consecutive destruction and demolition of the materials, usually metals and polymers, which is caused by chemical reactions, is called corrosion. During this process, purified materials turn into the oxide or sulfide. Corrosion destroys the material and weakens its strength.

Local rusting, spoiling the material and reducing the maintenance of steel members because of the displacement in bolt connections from humidity, can appear in the cable structures (Schock, 1997). Full linked high-density polyethylene (HDPE) strands coating and resins filling between them give the full relation of strands, as shown in Fig. 19 and protect cables from corrosion (Joye, 2010).

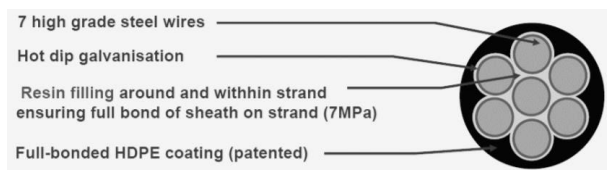

Fig. 19: Cohestrand solution (Joye, 2010)

To prevent or decrease the infiltration of moisture can be done by stuffing connections with non-acid silicone. In the parts of different types of metals combinations tufnol isolating bush and washer can help to avert the corrosion (Yan et al., 2016).

#### 4.5. Criteria of the stability

All cable structures must correspond to main stability criteria, which have been recapitulated in the Manual for structural applications of steel cables 2010 and Eurocode 3 Standards (Ačić et al., 2013).

**Criterion 1:** Cables have to be protected from corrosion and be relaxed.

**Criterion 2:** Multiplication of the maximum load should be less than effective strength.

**Criterion 3:** Movements of the structure should not be greater than the serviceability state.

**Criterion 4:** All of the system members should be tensioned.

**Criterion 5:** Resonance of the structure due to dynamic loads such as wind, traffic, earthquake, etc. should be evaded.

Criteria check on the building design stage can prevent the full structure from future collapse and reduction of steel members' maintenance.

### 5. Case study of Khan Shatyr Entertainment Center in Astana, Kazakhstan

Khan Shatyr Entertainment Center Fig. 20 is the cultural and social typed structure with the climatic shelter that proposes convenient microclimate all year in the Astana, second coldest capital of the world, with the temperature  $-35^{\circ}$  C in winter and  $+35^{\circ}$  C in summer. Building was opened in July 2010 and had the traditional nomadic tent form. Khan Shatyr means "the Tent of the Khan" or "largest tent." Project of this large scale cable structure was designed by Norman Foster.

150 m tall mast-stayed building has 200 m by 195 m elliptical base located at the north end of the city's axis, and it represents the highest point on the Astana skyline. Khan Shatyr is considered as the world's tallest tent structure. Total covered area is 100,000 m<sup>2</sup>, and it covers an urban-scale park with a 450 m running lane, shopping, and spare-time facilities such as restaurants, cinema, and entertainment areas for exhibitions and events. Landscape of the building is represented in green terraces, Water Park, wave swimming pools, and slides (Dancey, 2010).

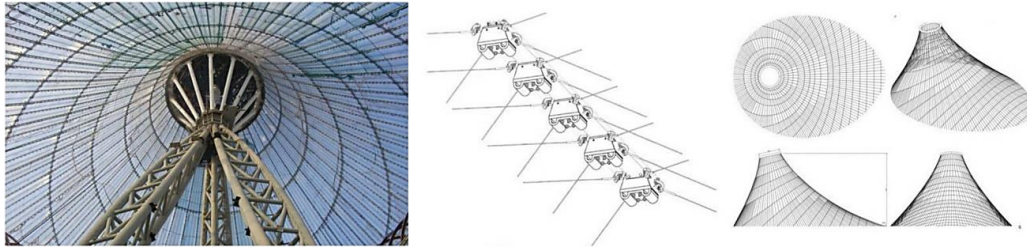

Fig. 20: View of the Khan Shatyr entertainment center (Nurumova, 2017)

To create large-scale columns free spaces with minimum supports engineers of Buro Happold designed a one-mast stayed cable net conical shape. It was the best choice according to the simplicity and potency of materials. With a compression mast to raise the net and form volume beneath, the roof, as well as approval for the building in the capital, in tension can use cables to transfer the loads. It produces a strong iconic shape on the skyline.

The cable net is shown in Fig. 21 consists of 16 circumferential and 192 radial cables. Circumferential cable diameters are 76 mm to increase the maintenance. For the system durability, they are installed in couples and promote the fixation between peripheral and radial cables. All cables are combined at the height 90 m on a ring at the vertex of the steel tripod and cover to the inclined concrete base of the building. Four crossing

bows set the 120 m wide and 140 m long wide roof structure.



**Fig. 21:** From left to right: 1-View of the cable (Nurumova, 2017); 2-Fixing brackets; 3-Model of cable structure (Birch, 2009)

The geometry of the net was chosen as the classic cone swayed to one side to bind to the internal disposal and to give the Khan Shatyr its specific architectural form. Prestressed against the hoop cables, radial ones embrace the top ring of the compression mast to the outer concrete base. 38 mm diameter 192 pairs of radial cables have a different length from 125 m at the front to 70 m at the back (Fig. 22). The hoop cables are situated perpendicular to the ridgeline. High pre-stress of 80 % of the peak forces is used in the structure to operate deviations nearly 800 mm over the longest cable so the roof can carry self-weight and snow/rain loads (BHE, 2015).

The peripheral cables are introduced to steady the radial cables by protracting against them and to hold the roof under the wind. To provide steadiness, the cable net is highly pre-stressed during assembling (DBC, 2014).



**Fig. 22:** Cables view (Nurumova, 2017)

Steel tripod in Fig. 23 is supporting the whole cable net structure. The main principle of its work is to give the single point support to the center of the cable net. The mast is pressed down at top and bottom and braced by the tent that it carries. Axle loads in the mast transfer with the tent under not symmetrical forces and decrease the vertex tension in the net.

Tripod consists of two 70 m long widened front legs and 60 m high vertical back leg. Legs are made from the triangular tubular steel trusses that organized from three-chord trusses with 1000 mm diameter round hollow sections. The back leg can withstand up to 140 MN, and the front leg confronts 50 MN. Three-legged mast affords on-site assembly of the stable ring in the air. The mast is fixed to the ground by means of central 7 meters' tall hub. Hub is made of 150 mm thick plate, maintaining 12 pins ended struts getting in touch with the cable net top

ring. Pin connections for the struts of 800 mm diameter give the joint of the top ring (Fig. 24).



**Fig. 23:** Tripod (Dancey, 2010)

The centerline of the hub conforms to the sequent axial load from the pre-stressed cable net. A 20 m diameter top ring made from a 1.6 m in diameter and 40 mm thick circular section. It is used to assemble all cables together (Birch, 2009).



**Fig. 24:** Hub and pin connection (Nurumova, 2017)

The tripod structure ensures steady constructible bottom, and the joint top ring gives displacement to reduce the loads in the cable net. The movable part of the mast is done as a small element for easy temporary bracing during assembly. Cable net structures are able to stir a bit to permit the cover material to change its form. On the top of the structure located an architectural hat in the form of a reversed cone made of insulated aluminum panels. It allows the tent to be ventilated and lightened during the night.

Radial cables were elevated separately into a flaccid mode with cable clamps attached fixed to receive the hoop cables located over the top of the radials. Tension is committed to cables by a jacking

detail at the base of the radial cables when all of them are fixed to form the net and to let the adjustment of the cushions to go on. The ETFE or ethylene tetrafluoroethylene cushions are put into extrusions from the ground and dragged to the top. The foil cushions have three layers fixed together and have an inflated middle layer. Entertainment Center has high insulation by filling the ETFE cushions with air to contain a high thermal range. Dimensions of each cushion are 3.5 m width by 30 m length. The length if it relies on the interval of the peripheral cables. They taper as the radial cables approach to the cone. The ETFE cushion panels are fixed to the cables with the aluminum clamping plates to endure the motion of the cables under climatic conditions. Flexible ETFE conducts with the cable net's diapason of stripping. The cables get closer, and the cushions change their form from an eye to a cylinder when the structure deviates. This motion bow the use of continuous edge extrusions paralleled to the hoop cables, which may produce shift collars. Shifting peripheral joints permit the structure to stir like a harmonica (Birch, 2009).

**6. Conclusion and recommendations**

The system of tension cables that carry the loads gives the opportunity for the architects to design wide free-column spaces. In other words, cable structures also are found to be long-living, and it is one of the opportunities for open-air spaces. Cables and structural elements of the system are usually made of different kinds of steel. Materials to be used with the main structure as cladding can vary from modern ETFE cushions to traditional wood.

The type of structures is needed to be chosen according to the site requirements and climatic conditions of the region because it is a significant rising requirement caused by global warming and climate change that we are facing in the last decades (Beyaz and Asilsoy, 2019) to consider nature impact for the cable structure design process.

Using the literature review in this article, the contemporary large scale cable structures, and construction methodology was investigated; the article shows that this type of structural system is suitable for all climatic regions. All the cable structures are incurred on the impact of climatic conditions. Underestimating this impact can negatively influence the health of cables and shorten the lifetime of the building. The article indicates the most important climatic problems to which architects and engineers should pay attention. Table 1 gives a summary review of possible solutions in the case of the nature impact on cable structural system.

**Table 1:** Climatic problems and their solutions

Climatic Problem	Possible Solutions
Vibration due to temperature change	<ul style="list-style-type: none"> <li>• Usage of dampers;</li> <li>• Vibration health monitoring;</li> <li>• Prestressing of cables.</li> </ul>
Wind Effect	<ul style="list-style-type: none"> <li>• The right choice of anchorage;</li> <li>• Crossed cables usage on double cables system;</li> <li>• The additional load on the roof;</li> <li>• Prestressing of secondary cables;</li> <li>• Usage of the beam – like rigid members.</li> </ul>
Corrosion	<ul style="list-style-type: none"> <li>• High – density polyethylene strands coating;</li> <li>• Resin filling of gaps;</li> <li>• Usage of non – acid silicone.</li> </ul>

Within this framework, Khan Shatyr Entertainment Center was examined as a case study. Evaluation of the study of Khan Shatyr Entertainment Center shows that climatic impact was properly considered on the design stage increases structure stability. The right choice of cladding material for the cold climate of Astana City influenced building efficiency and maintenance.

In addition, Table 2 shows the advantages and disadvantages of the cable structural system. We hope that this table can serve as a guide for architects in the choice of an appropriate system.

**Table 2:** Advantages and disadvantages of cable systems

Advantages	Disadvantages
<ul style="list-style-type: none"> <li>- Extremely lightweight;</li> <li>- Possibility of creating large scales and spans;</li> <li>- Impeded and open column-free spaces;</li> <li>- Easy and cheap construction due to the low weight of materials;</li> <li>- A minimum amount of structure;</li> <li>- Cost efficiency;</li> <li>- Design freedom;</li> <li>- Good resistance to fire;</li> <li>- Perform very well in earthquake zones;</li> <li>- Curved cable form and fabric construction methods diffuse sounds from inner and outer environment and absorb noise pollution;</li> <li>- The opportunity of lower energy cost with reduces solar energy and heat;</li> <li>- Translucent materials combined with structural cables provide a comfortable natural light source;</li> <li>- The semi-permanent nature of cable structural systems provides a potential for buildings future re-erection and relocation.</li> </ul>	<ul style="list-style-type: none"> <li>- Weak thermal and acoustic efficiency require additional precautions;</li> <li>- High moisture influence;</li> <li>- High wind influence;</li> <li>- Damage risks in case of mistakes during the construction process;</li> <li>- Expensive design process;</li> <li>- Difficulties in combination with existing structures from traditional materials;</li> <li>- Cable structures require good maintenance since dirt may be visible on facade and roof cladding.</li> </ul>

The following recommendations are offered for related research and practice in the field of cable structures:

1.Considering the changing nature of technology, a series of longitudinal studies, based on this model, would testify trends and thereby increase the



potential decisions regarding cable structures construction and monitoring would be relatively current and less exposed to personal prejudice.

2. While the current spheres of construction consider the technologies from a global viewpoint, it may be advantageous to conduct research based on the different locations of the cable buildings and diverse directions of inquiry such as chemistry, physics, materials innovations, nanotechnology, etc.
3. Vibration health monitoring (VHM), which uses the innate periodicity and mode forms as sensitive to damage features, can be used for the check of weakening of the cables, sagging of the bars, and the maintenance of the structure. This method can enhance the lifetime of the buildings.
4. Processes of the pretension and prestressing of the cables enlarge the stiffness and durability of the cables and whole structure.
5. Possibly use the Integrated Project Delivery method in all phases of cable structures design and construction.

### Compliance with ethical standards

### Conflict of interest

The authors declare that they have no conflict of interest.

### References

Ačić M, Lj V, and Kostić D (2013). Determination of prestressing levels for cable trusses as function of their stability. *Građevinar*, 65(12): 1097-1110. <https://doi.org/10.14256/JCE.863.2013>

Ashweare N and Eriksson A (2017). Vibration health monitoring for tensegrity structures. *Mechanical Systems and Signal Processing*, 85: 625-637. <https://doi.org/10.1016/j.ymssp.2016.08.039>

Behrends W (2015). Brand-Briesen airfield structure. In: Behrends W (Ed.), *The great airships of count zeppelin*: 110-111. Lulu, Morrisville, USA.

Beyaz C and Asilsoy B (2019). Knowledge of green buildings and environmental worldview among interior design students. *International Journal of Advanced and Applied Sciences*, 6(1): 29-36. <https://doi.org/10.21833/ijaas.2019.01.004>

BHE (2015). *A desert rose*. Buro Happold Engineering, Bath, UK. Available online at: <https://bit.ly/2TyFgRE>

Bing WB (2004). *Free-standing tension structures: From tensegrity systems to cable-strut systems*. Spon Press, London, UK. <https://doi.org/10.1201/9781482288308>

Birch A (2009). *Khan Shatyr entertainment center*. Available online at: <https://bit.ly/39qTCKw>

Boxer K and Scheuermann R (1996). *Tensile architecture in the urban context*. Architectural Press, New York, USA.

Cai CS, Wu WJ, and Araujo M (2007). Cable vibration control with a TMD-MR damper system: Experimental exploration. *Journal of Structural Engineering*, 133(5): 629-637. [https://doi.org/10.1061/\(ASCE\)0733-9445\(2007\)133:5\(629\)](https://doi.org/10.1061/(ASCE)0733-9445(2007)133:5(629))

Chan K (2016). *Expo'86 Canada pavilion: 21 vintage photos of Canada place*. Available online at: <https://bit.ly/2VBbSNf>

Dancey N (2010). *Grand opening of the Khan Shatyr Entertainment Center, Kazakhstan the world's tallest tensile structure*. Available online at: <https://bit.ly/2VAkZxV>

DBC (2014). *Khan Shatyr entertainment center*. Designing Buildings Co., London, UK. Available online at: <https://bit.ly/2wp4z0z>

Filler M (2015). *Frei otto's airborne architecture*. City Press, New York, USA.

Goldsmith N (2000). *Material for the new millennium*. In: Barnes M and Dickson M (Eds.), *Widespan roof structures*: 213-217. Thomas Telford Publishing, London, UK. <https://doi.org/10.1680/wrs.28777.0023>

Gossen P (2004). *Design with cables: Structural practices*. *Structure*, 8(1): 21-22.

Henrysson E (2012). *Conceptual design and analysis of membrane structures*. M.Sc. Thesis, Chalmers University of Technology, Göteborg, Sweden.

Joye S (2010). *Cable roofs*. In the 1<sup>st</sup> SoletancheBachy and Freyssinet Meeting, Soletanche Bachy and Freyssinet, Paris, France. Available online at: <https://bit.ly/2wiOHfg>

Koch KM (2004). *Membrane structures: Innovative building with film and fabric*. Prestel Verlag, Munich, Germany.

Lawson M and Bilyk A (2014). *Steel constructions in Architecture*. Ukrainian Center for Steel Construction, Kiev, Ukraine.

Macdonald AJ (2003). *Long span structures*. *Architecture Week Magazine*, Artifice, Inc., Eugene, USA.

Nerdinger W (2005). *Frei otto: Complete works: Lightweight construction, natural design*. Birkhäuser, Basel, Switzerland.

Nurumova K (2017). *Examination of large scale cable structures in different climate and proposals for Neu Lake and park*. M.Sc. Thesis, Graduate School of Applied Sciences of Near East University, Nicosia, Cyprus.

Oskoei SAG and McClure G (2008). *Dynamic analysis of cable roofs under transient wind: A comparison between time domain and frequency domain approaches*. *Tsinghua Science and Technology*, 13: 53-57. [https://doi.org/10.1016/S1007-0214\(08\)70126-3](https://doi.org/10.1016/S1007-0214(08)70126-3)

Phocas MC (2013). *Lightweight tensile structures towards an architectural-engineering integration*. *Journal of Architectural Engineering Technology*, 3(4). <https://doi.org/10.4172/2168-9717.S7-e001>

Sadek F, Mohraz B, Taylor AW, and Chung RM (1997). *A method of estimating the parameters of tuned mass dampers for seismic applications*. *Earthquake Engineering and Structural Dynamics*, 26(6): 617-635. [https://doi.org/10.1002/\(SICI\)1096-9845\(199706\)26:6<617::AID-EQE664>3.0.CO;2-Z](https://doi.org/10.1002/(SICI)1096-9845(199706)26:6<617::AID-EQE664>3.0.CO;2-Z)

Schock HJ (1997). *Soft shells: Design and technology of tensile architecture*. Birkhauser, Basel, Switzerland.

Seidel M (2009). *Tensile surface structures: A practical guide to cable and membrane construction*. John Wiley and Sons, Hoboken, USA. <https://doi.org/10.1002/9783433600269>

Vanderberg M (1998). *Cable nets: Detail in building*. Packard Publishing, Chichester, UK.

Warmbronn AFO (2015). *Institute for lightweight structures at the University of Stuttgart*. Lentz Verlag, Vaihingen, Germany. Available online at: <https://bit.ly/2VCrjvi>

Yan H, Yuan Y, and Yu J (2016). Fatigue reliability analysis of cable considering corrosion. *Procedia Engineering*, 166: 127-135.

<https://doi.org/10.1016/j.proeng.2016.11.575>