

DFIG control: A fuzzy approach

Alnufaie Lafi *



College of Engineering, Shaqra University, Shaqraa, Saudi Arabia

ARTICLE INFO

Article history:

Received 18 March 2019

Received in revised form

10 July 2019

Accepted 16 July 2019

Keywords:

DFIG

Wind energy conversion system

Fuzzy control

ABSTRACT

In this paper, we are going to discuss the fuzzy logic techniques and their importance in the control of the nonlinear systems. The double fed Induction generator (DFIG) is widely used in wind energy conversion systems. The control of DFIG is very complicated due to its strong nonlinearities. The first case is a controller with 3 sets in inputs and outputs. The second case is a controller with 5 sets in inputs and outputs. The third case is a controller with 7 sets in inputs and outputs. The objective of this paper is to propose a new control strategy based on fuzzy logic in order to control the power of the wind turbine and make it adaptable to different constraints. A simulation study is done to validate this control strategy.

© 2019 The Authors. Published by IASE. This is an open access article under the CC BY-NC-ND license (<http://creativecommons.org/licenses/by-nc-nd/4.0/>).

1. Introduction

Renewable energy resources represent an alternative solution to encounter the growing energy needs of our society, and to reduce environmental issues due to fossil fuels consumption. Renewable sources can be used to produce energy again and again i.e. solar energy, wind energy, geothermal energy, marine energy, biomass energy, biofuels, and many more. Renewable energy sources have the ability to provide energy free of air pollutants and greenhouse gasses by emitting zero or nearly zero percent of these gasses (Ebeed et al., 2013). Wind power systems provide several benefits including electrical energy production and reliability improvements. Thanks to recent progress in modern power electronics, a wind turbine with a doubly fed induction generator (DFIG) has drawn increasing attention. In the DFIG, the induction generator is grid-connected at the stator as well as at the rotor mains via a converter (Ismail and Bendary, 2016). The oriented vector control was widely applied to the rotor side converter of the DFIG. This allows using classical methods to active and reactive powers of the machine (Alaboudy et al., 2013; Wang et al., 2015). Nevertheless, these methods are not robust due to the presence of nonlinearities and uncertainties. In contrast to the conventional control theory, which is based on the system mathematical

models, fuzzy control is a kind of model-free control by incorporating linguistic information from human experts. In this context, we propose to use a fuzzy controller for power regulation for a DFIG (Tapia et al., 2003; Yang et al., 2012; Hussain et al., 2017). We will show the effect of the number of used fuzzy sets on system performances. The rest of paper is organized as follows: After the wind energy conversion system modeling, we present the fuzzy controller design. Before concluding, several simulation results are presented to confirm our objectives (Mi et al., 2004; Agarwal et al., 2009).

2. Wind energy conversion system modeling

The synoptic scheme of the studied system is shown in Fig. 1. It is composed of a wind turbine, a doubly fed induction Generator (DFIG), a diode rectifier, a filter and a PWM controlled inverter (Kesraoui et al., 2011).

2.1. Wind turbine model

As presented in, the turbine power and developed torque are given by the following expressions:

$$P_m = \frac{1}{2} \rho \pi R^2 v^3 C_p(\lambda) \quad (1)$$

$$T_m = \frac{P_m}{\Omega} = \frac{1}{2\lambda} \rho \pi R^3 v^2 C_p(\lambda) \quad (2)$$

where, ρ is air density; R is blade length; v is wind speed; C_p is power coefficient; Ω is turbine angular speed; $\lambda = \frac{\Omega R}{v}$ is the ration between the turbine angular speed and the wind speed. Its value is given by the manufacturer and can be defined by a mathematical approximation.

* Corresponding Author.

Email Address: alnufaie@su.edu.sa<https://doi.org/10.21833/ijaas.2019.09.015>

Corresponding author's ORCID profile:

<https://orcid.org/0000-0003-2453-2637>

2313-626X/© 2019 The Authors. Published by IASE.

This is an open access article under the CC BY-NC-ND license

<http://creativecommons.org/licenses/by-nc-nd/4.0/>

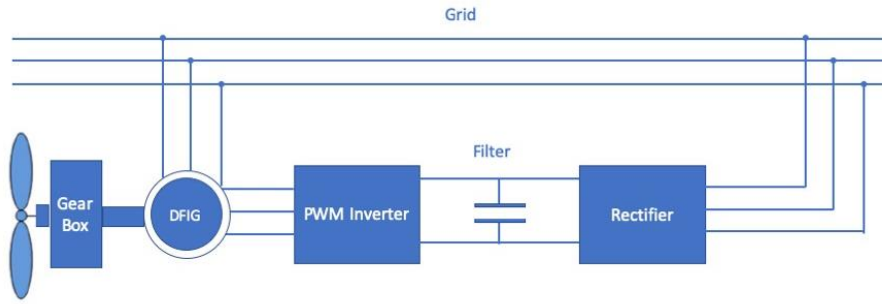

Fig. 1: Synoptic of the studied system

2.2. DFIG model

To convert the wind power to electrical one, we have chosen to use a DFIG generator due to its high energy efficiency, reduced mechanical stress on the wind turbine, and relatively low power rating of the connected power electronics converter of low costs (Bouscayrol et al., 2005; Vlad et al., 2010). The model of the DFIG is expressed in the (d-q) reference frame by the following equations:

2.2.1. Electrical equations

The DFIG mathematical model is analyzed in the dq reference frame and is defined by the following equations:

$$\begin{cases} V_{ds} = R_s i_{ds} + \frac{d}{dt} \varphi_{ds} - \omega_s \varphi_{qs} \\ V_{qs} = R_s i_{qs} + \frac{d}{dt} \varphi_{qs} + \omega_s \varphi_{ds} \\ V_{dr} = R_r i_{dr} + \frac{d}{dt} \varphi_{dr} - \omega_r \varphi_{qr} \\ V_{qr} = R_r i_{qr} + \frac{d}{dt} \varphi_{qr} + \omega_r \varphi_{dr} \end{cases} \quad (3)$$

where, R_s is stator resistance; φ_{ds} is direct stator flux; ω_s is electrical speed of stator; φ_{qs} is quadrature stator flux; R_r is rotor resistance; φ_{dr} is direct rotor flux; ω_r is electrical speed of rotor; φ_{qr} is quadrature rotor flux.

2.2.2. Flux linkage equations

The electromagnetic torque depends on dq flux and the currents:

$$\begin{cases} \varphi_{ds} = L_s i_{ds} + M_{sr} i_{dr} \\ \varphi_{qs} = L_s i_{qs} + M_{sr} i_{qr} \\ \varphi_{dr} = L_r i_{dr} + M_{sr} i_{ds} \\ \varphi_{qr} = L_r i_{qr} + M_{sr} i_{qs} \end{cases} \quad (4)$$

where, L_s is stator inductance; M_{sr} is mutual inductance; L_r is rotor inductance.

2.2.3. Mechanical equation

The mechanical equation for the model DFIG is:

$$J \frac{d}{dt} \Omega = T_w - T_e - B \Omega \quad (5)$$

where, J is moment of inertia; T_w is wind torque; T_e is electromagnetic torque; B is damping coefficient.

$$T_e = p(\varphi_{ds} i_{qs} - \varphi_{qs} i_{ds}) \quad (6)$$

where, p is pair number of poles.

3. Control strategy

To control the DFIG simply, we should guarantee an independent control of active and reactive powers via stator flux orientation. For this, we align the stator flux along the axis (d) of the rotating frame, which can be expressed as:

$$\begin{cases} \varphi_{ds} = \varphi_s \\ \varphi_{qs} = 0. \end{cases} \quad (7)$$

Furthermore, we assume that the stator is supplied by a stable grid and its resistance can be neglected. Then, we can obtain:

$$\begin{cases} V_{qs} = V_s \\ V_{ds} = 0. \end{cases} \quad (8)$$

Otherwise, the active and reactive powers are given by the following expressions:

$$\begin{cases} P_s = V_{ds} i_{ds} + V_{qs} i_{qs} \\ Q_s = V_{qs} i_{ds} - V_{ds} i_{qs}. \end{cases} \quad (9)$$

According to Eqs. 7 and 8 and the considered simplifications, Eq. 9 becomes:

$$\begin{cases} p_s = -V_s \frac{M_{sr}}{L_s} i_{qr} \\ Q_s = -V_s \frac{M_{sr}}{L_s} i_{dr} + \frac{V_s \varphi_s}{L_s} \end{cases} \quad (10)$$

Fig. 2 gives the synoptic scheme of the simplified model of Eq. 10.

4. Fuzzy logic control design

Given its many applications in the industrial world and the large number of research work developed, fuzzy logic is a very good solution for controlling nonlinear systems without the requirement of their mathematical model. General configuration of FLC consist of following four stages namely:

- Fuzzification: allows to transform numerical inputs to fuzzy ones,
- Rule base: a collection of rules in form of IF-Then describing the human making decision.

- Fuzzy inference: a mechanism allowing to exploit fuzzy rule base to calculate the linguistic output.
- Defuzzification: converts the inferred decision from the linguistic variables back the numerical values.

Fig. 3 gives basic configuration a fuzzy logic controller. In this work, we use two fuzzy logic controllers for active and reactive powers regulation.

For each fuzzy controller, we use the error and its time derivative. For fuzzification we adopt Gaussian fuzzy sets. Three cases will be studied: 3, 5 and 7 fuzzy sets for each input. Mamdani's MAX-MIN manner is considered as the inference method, in which there are several methods for interface engine, while the center of gravity is used for the defuzzification process. The bloc diagram of the proposed control is given by Fig. 4.

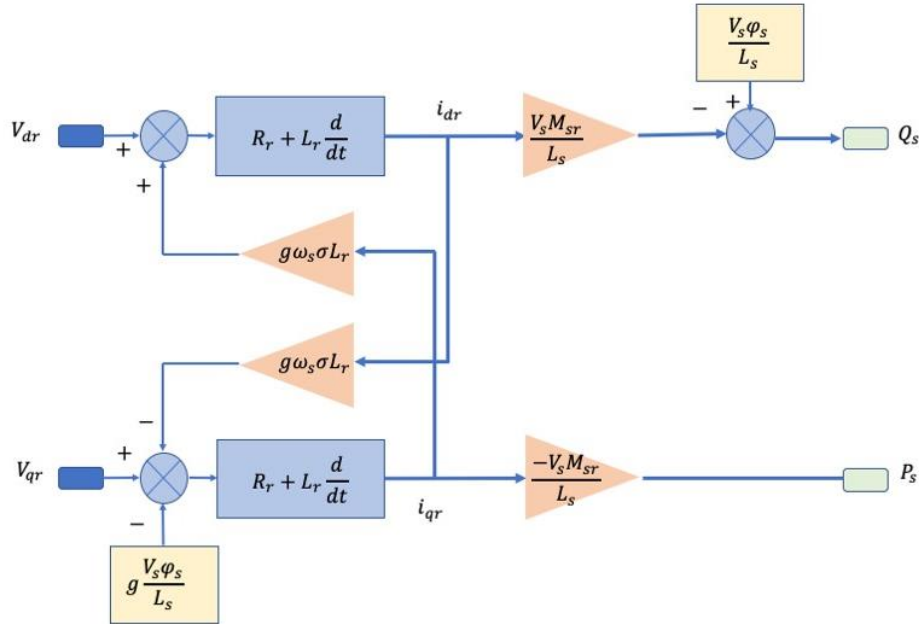

Fig. 2: Simplified model of DFIG



Fig. 3: Basic configuration a fuzzy logic controller

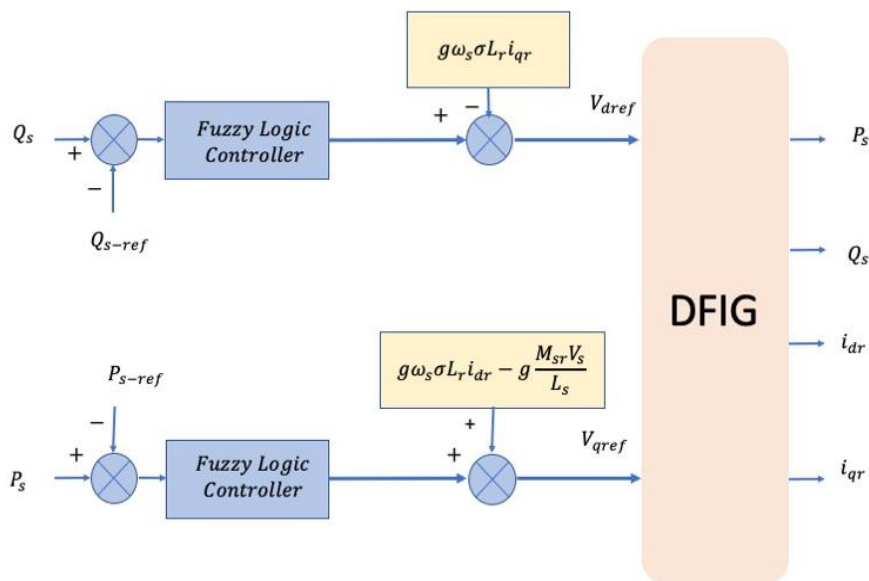

Fig. 4: The bloc diagram of the proposed control

4.1. Case 1: Fuzzy controller with 3 sets in inputs and outputs

Fig. 5 show the membership functions of the inputs: error (e) and variation of error (de), and the output (u). Here N is negative, Z is zero, P is positive (Amine et al., 2014).

Table 1 shows the rules base. The rows represent the rate of the error e and the columns represent error change \dot{e} . Each pair (e, \dot{e}) determines the output level NB to PB corresponding to u.

4.2. Case 2: Fuzzy controller with 5 sets in inputs and outputs

Fig. 6 shows the membership functions of the inputs: error (e) and the change of error (de), and

the output (u). Here NB is negative big, N is negative, Z is zero, P is positive and PB is positive big, are labels of fuzzy sets and their corresponding membership functions (Amine et al., 2014).

Table 1: Rules base

u		de		
		N	Z	P
e	N	N	N	Z
	Z	N	Z	P
	P	Z	P	P

Table 2 shows the rules base. The rows represent the rate of the error change e and the columns represent the error (e). Each pair (e, \dot{e}) determines the output level GN (Big Negative) to GP (Big Positive) corresponding to u.

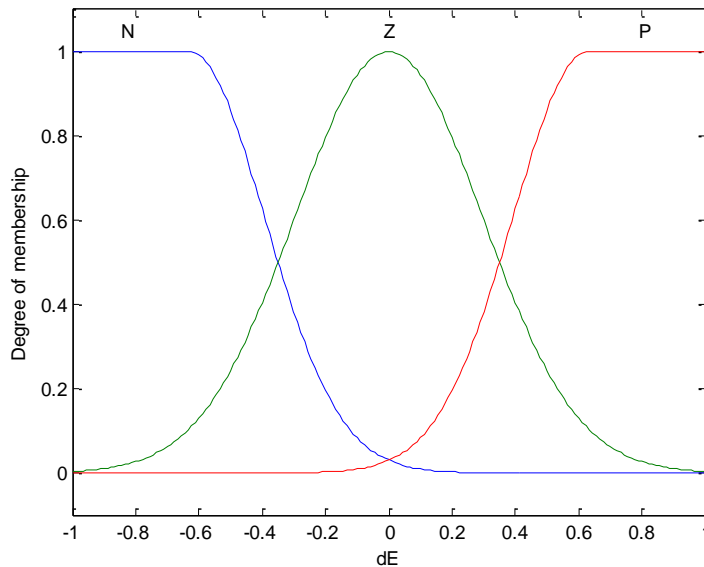
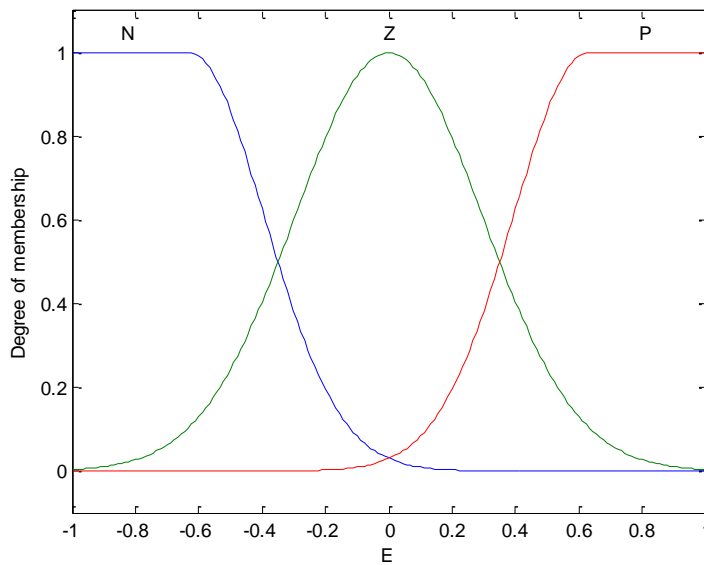

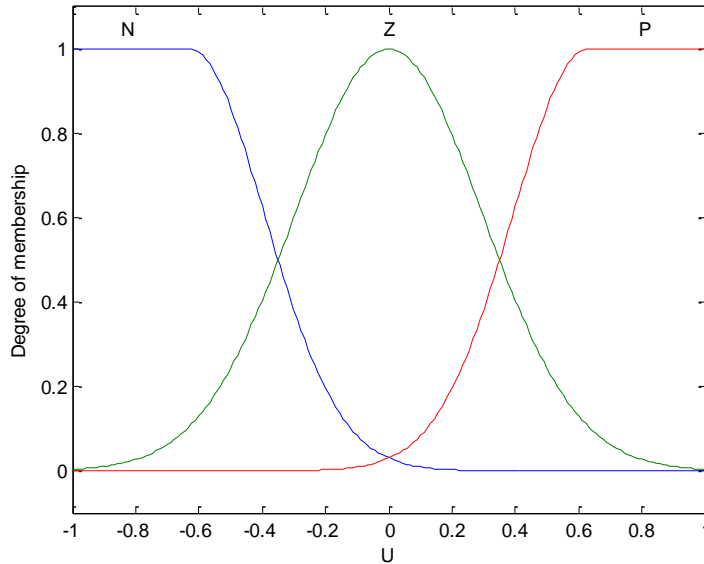

Fig. 5: Fuzzy sets of e, de and u

4.3. Case 3: Fuzzy controller with 7 sets in inputs and outputs

Fig. 7 show the membership functions of the inputs: error (e) and the change of error (de), and the output (u). Here NB is negative big, NM is negative medium, NS is negative small, Z is zero, PS is positive small, PM is positive medium and PB is positive big, are labels of fuzzy sets and their corresponding membership functions. Table 3 gives the rules base of corresponding fuzzy controller (Thongam et al., 2011; Amine et al., 2014).

5. Simulation and results

In this section, we have simulated, in Matlab-Simulink, the system described in Fig. 4. For simplicity, we have supposed that the inverter is perfect. First, we have simulated the system as it is described in Fig. 4. To extract the maximum power that can be generated by the DFIG. The desired active

power is the one that can be delivered by the wind turbine.

Table 2: Rules base

u	de					
	GN	N	Z	P	GP	
e	GN	GN	GN	N	N	Z
	N	GN	N	N	Z	P
	Z	N	N	Z	P	P
	P	N	Z	P	P	GP
	GP	Z	P	P	GP	GP

Table 3: Rules base of fuzzy controller

u	de						
	NB	NM	NS	Z	PS	PM	PB
e	NB	NB	NB	NB	NM	NS	Z
	NM	NB	NB	NB	NM	NS	Z
	NS	NB	NB	NM	NS	Z	PS
	Z	NB	NM	NS	Z	PS	PM
	PS	NM	NS	Z	PS	PM	PB
	PM	NS	Z	PS	PM	PB	PB
	PB	Z	PS	PM	PB	PB	PB

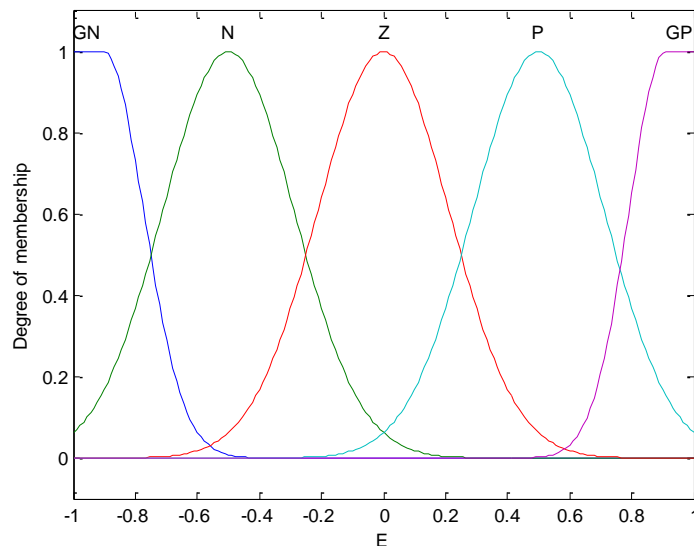

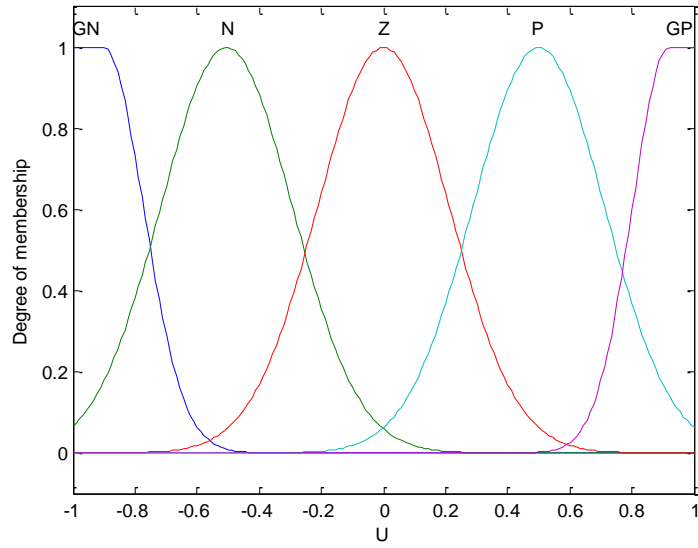
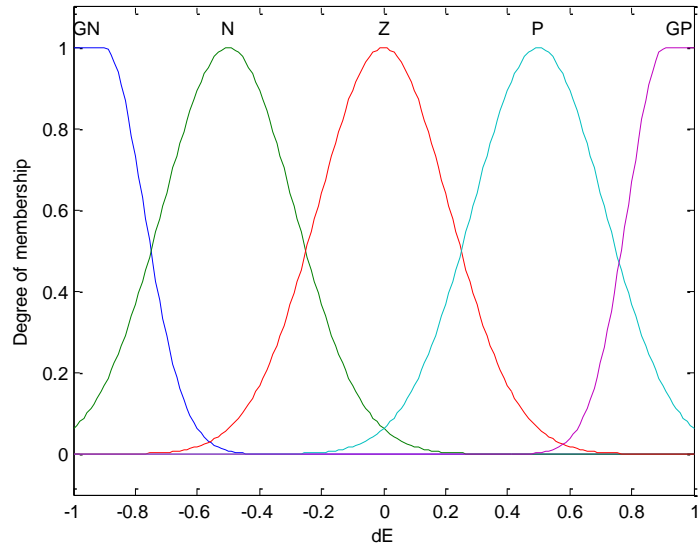
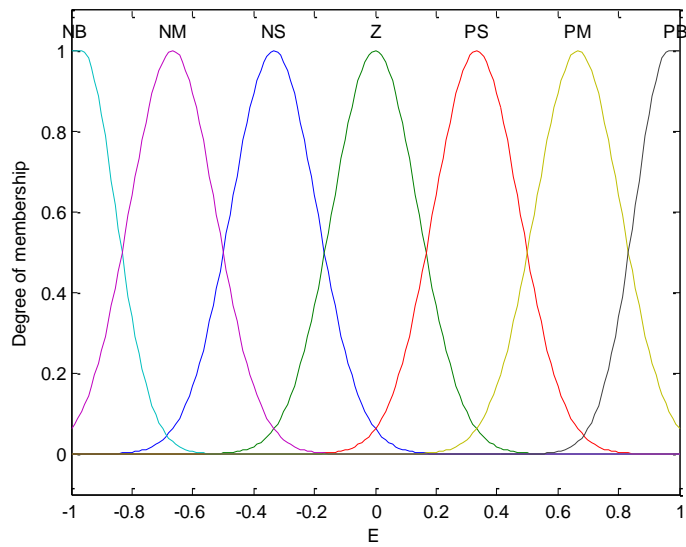

Fig. 6: Fuzzy sets of e, de and u



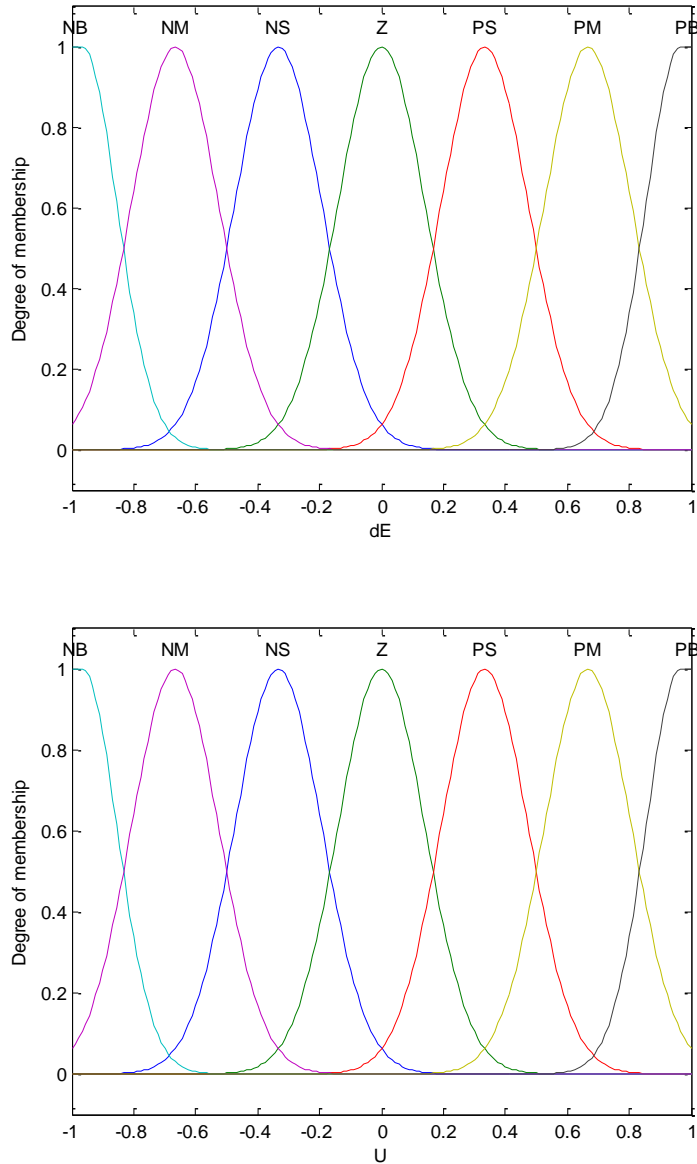

Fig.7: Membership functions: error (e), Δe , and output u

For simulation, the following parameters have been used:

DFIG Parameters: Rated output power 7,5 kW, Rated phase voltage 400V, $f=50\text{Hz}$, $p=2$, $R_r=0.62\Omega$, $R_s=0.455\Omega$, $L_r=0.081\text{H}$, $L_s=0.084\text{H}$, $M_{sr}=0.078\text{H}$, $J=0.3125\text{ kg.m}^2$, $f=0.00673\text{ N.m/s}$.

Fig. 8 shows that using Fuzzy logic technique allowed us to have high performances to follow the desired trajectory without overshoot and good accuracy. The number of fuzzy sets used to describe each fuzzy variable (inputs and output) has a great impact on the number of rules in the inference bloc, and then on the performance of the fuzzy logic controller. The fuzzy logic controller with seven fuzzy sets (49 rule) has more accuracy than with five fuzzy sets (25 rules).

Fig. 9 shows the test of robustness in the case of variation of rotor resistance (+50%), the response of system shows the robustness of the fuzzy controller, in tracking the desired trajectory even in the presence of intern or extern disturbances.

6. Conclusion

In this paper, we have interested to the design of the fuzzy logic controller to the control the power generated by the wind turbine based on a DFIG. The simulation results show the possibility of the control of the power generated by the DFIG to the grid by controlling the rotor voltages and the high performances of the controller based on fuzzy logic. Future works will be dedicated to type-2 fuzzy logic to enhance the robustness of our controller.

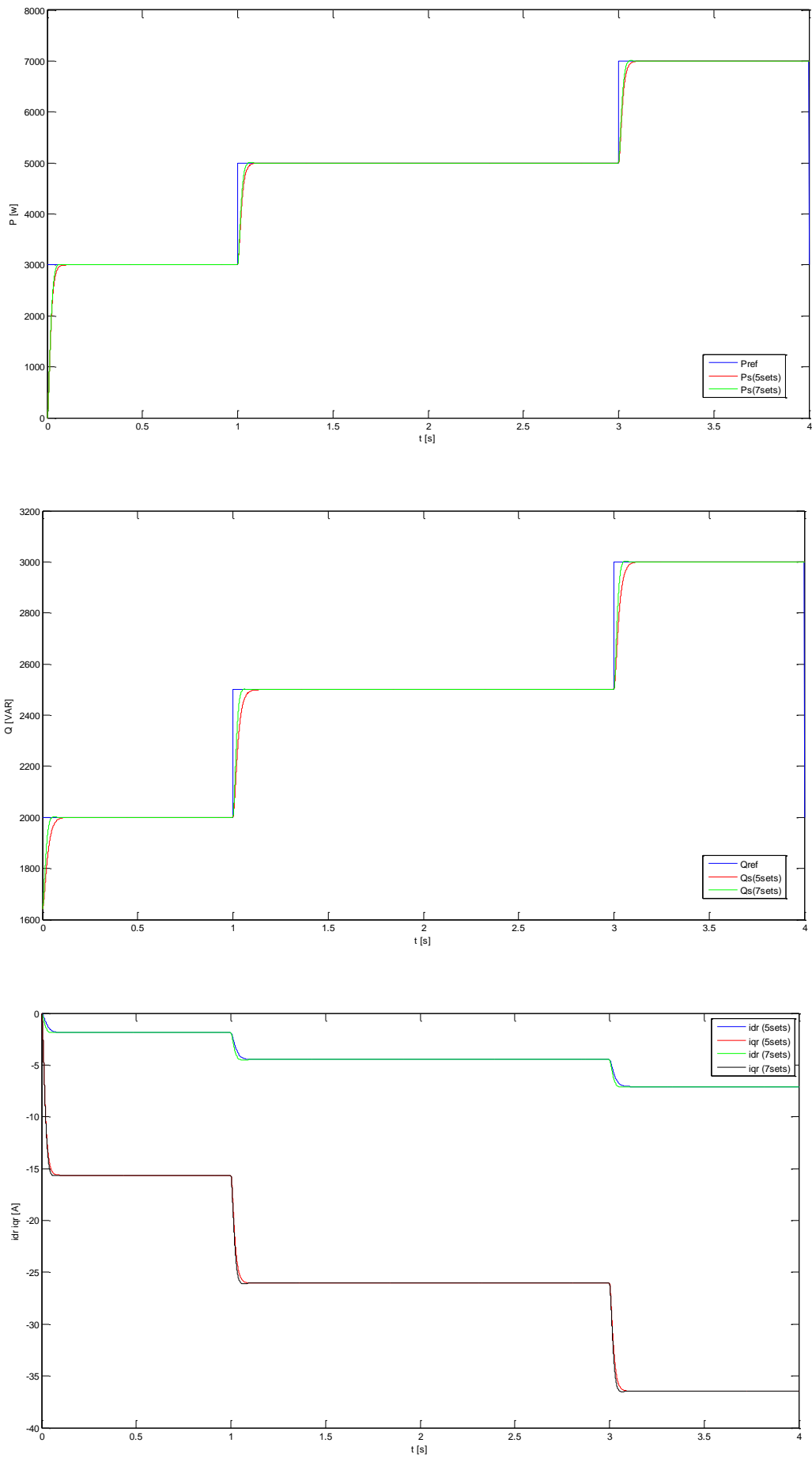

Fig. 8: Response of the system when using power Fuzzy logic controller

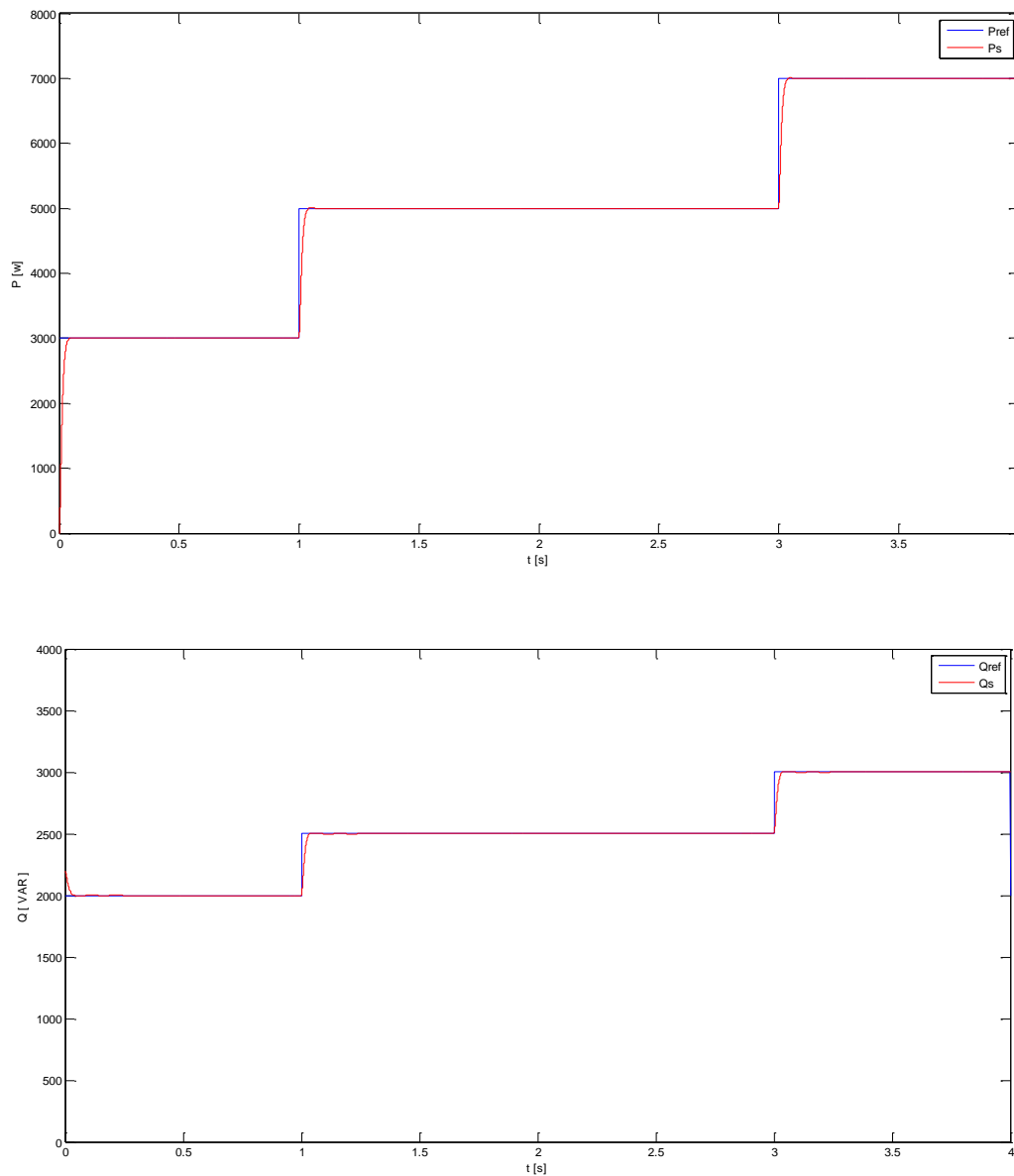

Fig. 9: Test of robustness in the case of variation of R_r (+ 50%)

Compliance with ethical standards

Conflict of interest

The authors declare that they have no conflict of interest.

References

Agarwal V, Aggarwal RK, Patidar P, and Patki C (2009). A novel scheme for rapid tracking of maximum power point in wind energy generation systems. *IEEE Transactions on Energy Conversion*, 25(1): 228-236. <https://doi.org/10.1109/TEC.2009.2032613>

Alaboudy AHK, Daoud AA, Desouky SS, and Salem AA (2013). Converter controls and flicker study of PMSG-based grid connected wind turbines. *Ain Shams Engineering Journal*, 4(1): 75-91. <https://doi.org/10.1016/j.asej.2012.06.002>

Amine BM, Souhila Z, and Tayeb A (2014). Adaptive fuzzy logic control of wind turbine emulator. *International Journal of*

Power Electronics and Drive Systems, 4(2): 241-255. <https://doi.org/10.11591/ijped.v4i2.5809>

Bouscayrol A, Delarue P, and Guillaud X (2005). Power strategies for maximum control structure of a wind energy conversion system with a synchronous machine. *Renewable Energy*, 30(15): 2273-2288. <https://doi.org/10.1016/j.renene.2005.03.005>

Ebeed M, NourEldeen O, and Ebrahim AA (2013). Assessing behavior of the Outer Crowbar Protection with the DFIG during grid fault. In the 2nd International Conference on Energy Systems and Technologies, Cairo, Egypt: 18-21.

Hussain A, Arif SM, and Aslam M (2017). Emerging renewable and sustainable energy technologies: State of the art. *Renewable and Sustainable Energy Reviews*, 71: 12-28. <https://doi.org/10.1016/j.rser.2016.12.033>

Ismail MM and Bendary AF (2016). Protection of DFIG wind turbine using fuzzy logic control. *Alexandria Engineering Journal*, 55(2): 941-949. <https://doi.org/10.1016/j.aej.2016.02.022>

Kesraoui M, Korichi N, and Belkadi A (2011). Maximum power point tracker of wind energy conversion system. *Renewable Energy*, 36(10): 2655-2662. <https://doi.org/10.1016/j.renene.2010.04.028>

- Mi C, Filippa M, Shen J, and Natarajan N (2004). Modeling and control of a variable-speed constant-frequency synchronous generator with brushless exciter. *IEEE Transactions on Industry Applications*, 40(2): 565-573.
<https://doi.org/10.1109/TIA.2004.824504>
- Tapia A, Tapia G, Ostolaza JX, and Saenz JR (2003). Modeling and control of a wind turbine driven doubly fed induction generator. *IEEE Transactions on Energy Conversion*, 18(2): 194-204.
<https://doi.org/10.1109/TEC.2003.811727>
- Thongam JS, Bouchard P, Beguenane R, Okou AF, and Merabet A (2011). Control of variable speed wind energy conversion system using a wind speed sensor less optimum speed MPPT control method. In the IECON 2011-37th Annual Conference of the IEEE Industrial Electronics Society, IEEE, Melbourne, Australia: 855-860.
<https://doi.org/10.1109/IECON.2011.6119422>
- Vlad C, Munteanu I, Bratcu AI, and Ceangă E (2010). Output power maximization of low-power wind energy conversion systems revisited: Possible control solutions. *Energy Conversion and Management*, 51(2): 305-310.
<https://doi.org/10.1016/j.enconman.2009.09.026>
- Wang Y, Phung BT, and Ravishankar J (2015). Fault analysis of an islanded micro-grid with doubly fed induction generator based wind turbine. In the International Conference on Electricity Distribution, CIRED, Lyon, France: 1-5.
- Yang L, Xu Z, Ostergaard J, Dong ZY, and Wong KP (2012). Advanced control strategy of DFIG wind turbines for power system fault ride through. *IEEE Transactions on Power Systems*, 27(2): 713-722.
<https://doi.org/10.1109/TPWRS.2011.2174387>